

elettropiloti 10 mm su base multiconnessione

10 mm solenoid valves on manifold with multiconnection D-SUB

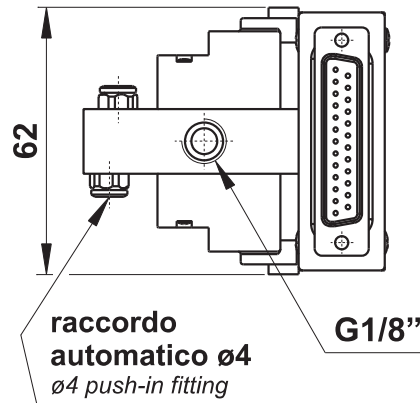

- Ingresso aria da entrambi i lati
Air inlet from both sides
- Uscite con raccordo automatico per tubo $\varnothing 4$
Exits with $\varnothing 4$ push-in fittings
- Montaggio a pannello mediante due viti M3 nella parte superiore
Panel mounting possible with two M3 screws on the top side
- Elettropiloti 3/2
3/2 solenoid valves
- Protezione elettrica IP40
Electrical protection IP40
- Connettore D-SUB (DB-25) a 25 poli
Connector D-SUB (DB-25) with 25 pins
- Base e struttura in alluminio
Manifold and structure in aluminium



n. 2 fori $\varnothing 3.5$
per fissaggio a pannello
n. 2 holes $\varnothing 3.5$
for panel mounting

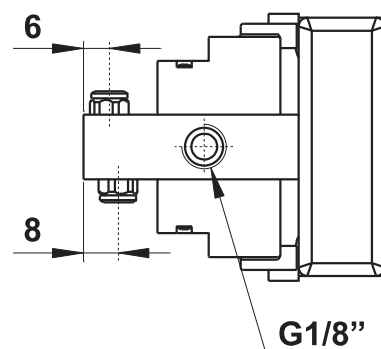
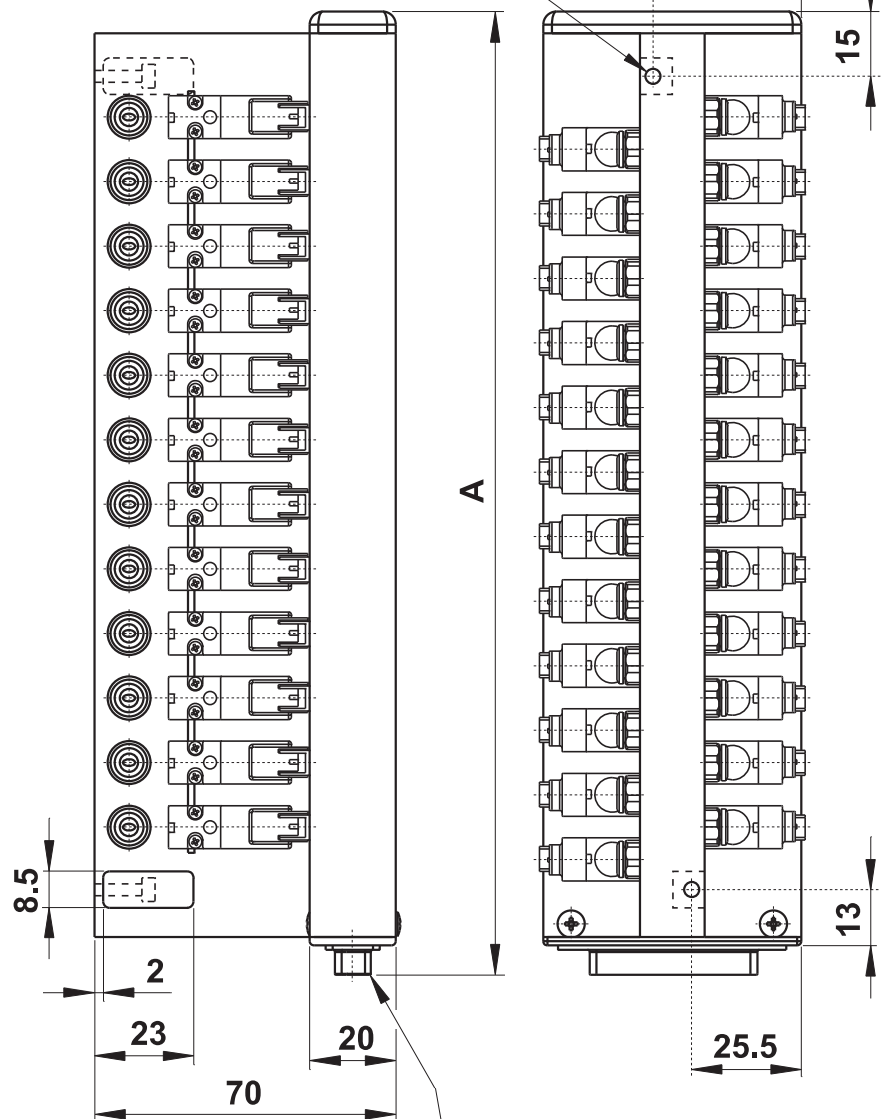

connettore D-SUB (DB-25)
D-SUB connector (DB-25)

modello model	nr. posiz. no. stations	A
07.012.4	4	67
07.013.4	6	82
07.014.4	8	97
07.015.4	10	112
07.016.4	12	127
07.017.4	14	142
07.018.4	16	157
07.019.4	18	172
07.020.4	20	187
07.021.4	22	202
07.022.4	24	217

elettropiloti 10 mm su base multiconnessione

10 mm solenoid valves on manifold with multiconnection D-SUB



Elettropilota
Solenoid valve **10 mm**

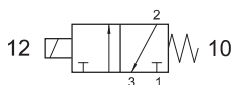

00.441.0

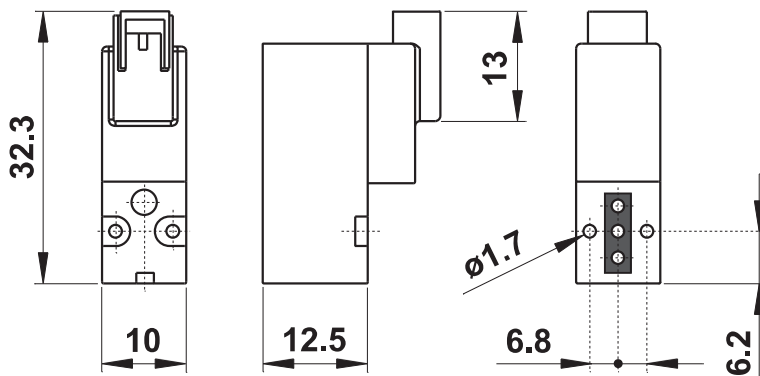
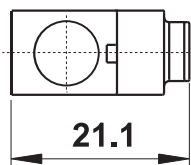

Attenzione: momento massimo di serraggio delle viti di fissaggio degli elettropiloti sulla base: 0.25 Nm
Attention: maximum torque for mounting screws of the solenoid valves: 0.25 Nm

ACCESSORI - ACCESSORIES

07.049.0 Connettore per elettropilota 10 mm con cavetto rosso/nero, lunghezza 400 mm
Connector for 10 mm solenoid with cable red/black, length 400 mm

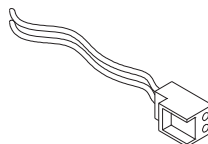

numerazione elettropiloti valves numbering

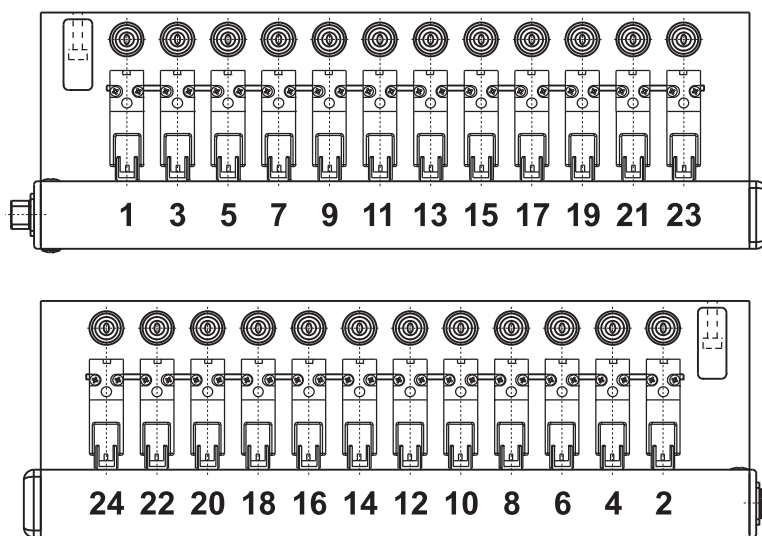

connettore D-SUB (DB-25) connector D-SUB (DB-25)

1-24 segnali per elettropiloti
signals for solenoid valves

25 comune (-)
common (-)

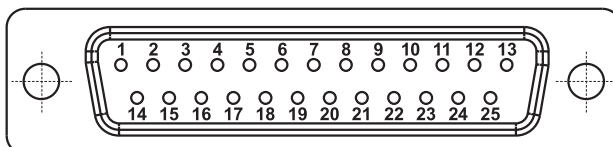

Tensione <i>Tension</i>	24V DC \pm 10%
Potenza <i>Power</i>	0.5 ... 1 W
Portata nominale a 6 bar, Δp 1 bar <i>Nominal flow rate at 6 bar, Δp 1 bar</i>	15 NI/min
Temperatura di esercizio <i>Temperature range</i>	-5°C ... +60°C
Pressione di esercizio <i>Working pressure</i>	0 ... 7 bar 0 ... 0.7 MPa
Fluido <i>Fluid</i>	Aria filtrata 5 μ con o senza lubrificazione 5 μ filtered, lubricated or non lubricated air

elettropiloti 10 mm su base multiconnessione

10 mm solenoid valves on manifold with multiconnection D-SUB



staffa per fissaggio base

mounting bracket

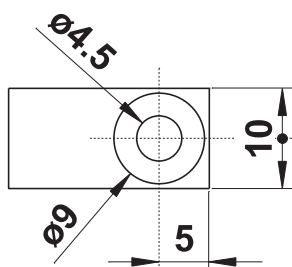
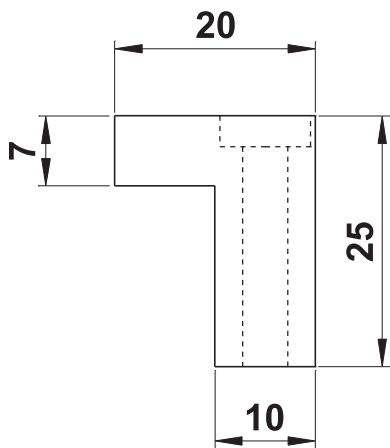

CODICE DI ORDINAZIONE
ORDER CODE

07.051.2



Utilizzabile per fissare la base su un piano. Il codice di ordinazione si riferisce a una coppia di staffe, venduta in kit con le viti necessarie per l'assemblaggio.

It can be used to mount the base on a plate. The order code is referred to a couple of brackets, which are sold in kit with the assembling screws.

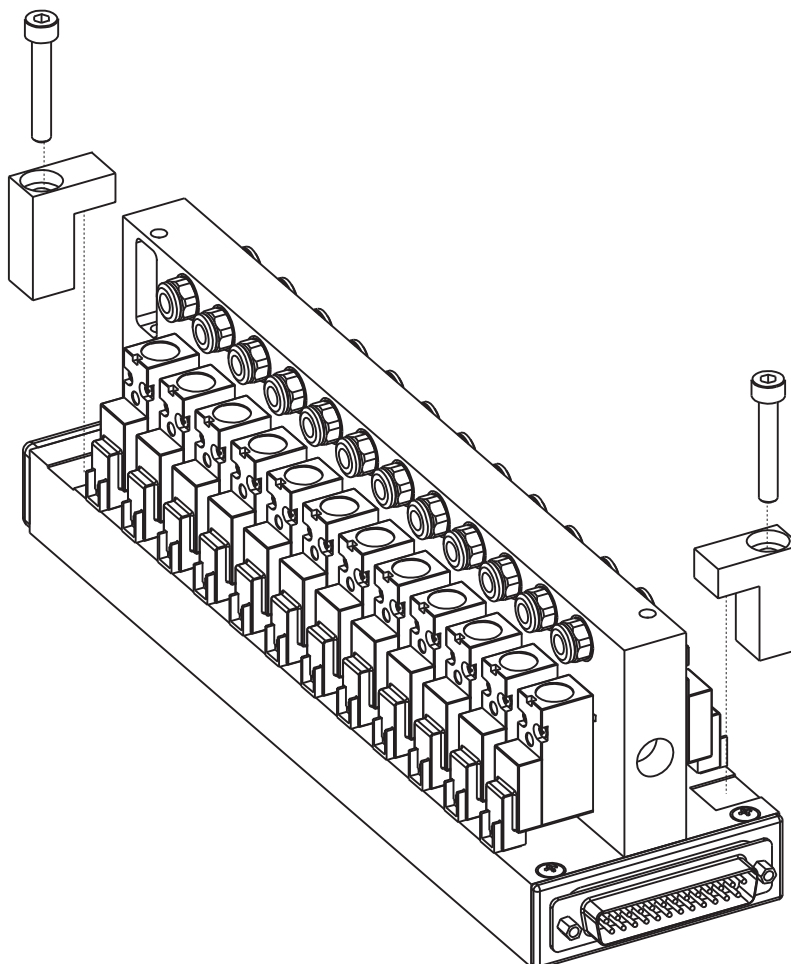

multiconnessione plug-in compatta

compact plug-in multiconnection



- Valvole a spola 5/2 con attacchi filettati G1/8"
5/2 spool valves with G1/8" threaded ports
- Comandi elettrici con azionamento manuale
Solenoid pilots with manual override
- Tensione 24V DC
Tension 24V DC
- Protezione elettrica IP 40
Electrical protection IP 40
- Potenza 0.5 ... 1W
Power 0.5 ... 1W
- Massimo 12 valvole bistabili o 24 monostabili
Maximum 12 bi-stable valves or 24 mono-stable
- Entrata e uscite: G1/8"; scarichi: M5
Air supply and exit ports: G1/8"; exhaust ports: M5

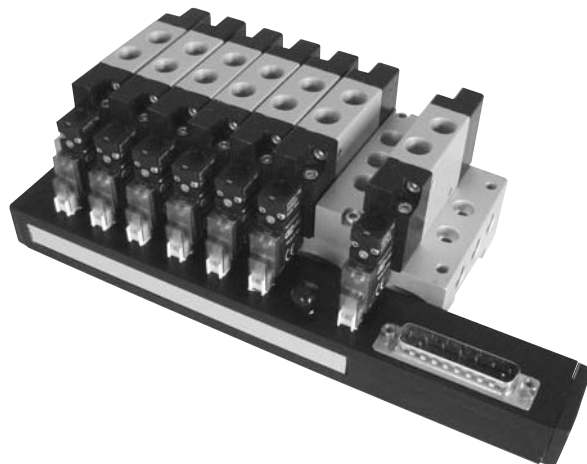

Materiali

Corpo: alluminio 11S

Molle: INOX

Guarnizioni: NBR

Spola: alluminio nichelato

Parti interne: ottone OT58

Materials

Body: aluminium 11S

Springs: stainless steel

Seals: NBR

Spool: nickel plated aluminium

Internal parts: brass OT58

Diametro nominale <i>Nominal orifice</i>		4 mm	
Portata nominale a 6 bar, Δp 1 bar <i>Nominal flow rate at 6 bar, Δp 1 bar</i>		350 NI/min	
Temperatura di esercizio <i>Temperature range</i>		-5 ... +60°C	
Pressione di esercizio <i>Working pressure</i>	al. interna monost. [monost. internal air supply]	al. interna bist. [bi-stable internal air supply]	alim. separata [separate air supply]
	2.5 ... 7 bar 0.25 ... 0.7 MPa	2.5 ... 7 bar 0.25 ... 0.7 MPa	-0.9 ... 10 bar -0.09 ... 1 MPa
Pressione di azionamento (per alimentazione separata) <i>Actuating pressure (for separate air supply)</i>		monostabile [mono-stable]	bistabile [bi-stable]
		2.5 ... 7 bar 0.25 ... 0.7 MPa	2.5 ... 7 bar 0.25 ... 0.7 MPa
Fluido <i>Fluid</i>		Aria filtrata 5 μ con o senza lubrificazione <i>5μ filtered, lubricated or non lubricated air</i>	

chiave di codifica

key to codes

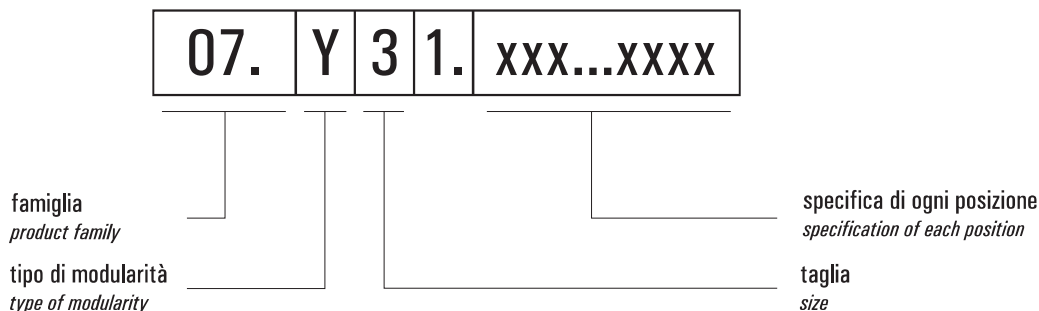

Famiglia *[product family]*

07 multiconnessione plug-in *[plug-in multiconnection]*

Tipo di modularità *[type of modularity]*

Y sottobasi modulari *[modular multiple sub-bases]*

Taglia *[size]*

3 G1/8" 16 mm

Specifica di ogni posizione *[specification of each position]*

**RISPETTARE MAIUSCOLE E MINUSCOLE
CASE SENSITIVE**

G1/8"

- a** 451P ME
- b** 451P ME AS
- c** 451P EE
- e** 451P EE AS
- q** 451P CE
- r** Piastrina di chiusura *[blanking plate]*
- s** Intermedio *[intermediate header]*
- t** Diaframma alimentazione
[diaphragm on air supply]
- u** Diaframma scarichi
[diaphragm on exhausts]
- v** Diaframma alimentazione + scarichi
[diaphragm on air supply and exhausts]

Le valvole, le parti elettroniche e le sottobasi con i relativi elementi accessori sono compresi e premontati nella multiconnessione ordinata secondo la presente chiave di codifica, non è pertanto necessario ordinarli separatamente.

Valves, electronic parts and sub-bases with accessories are included and preassembled in the multiconnection manifold ordered according to these codes. It is not necessary to order them separately.

multiconnessione plug-in compatta

compact plug-in multiconnection



451P ME

5/2 1/8" comando elettrico - ritorno a molla
5/2 1/8" solenoid pilot - spring return

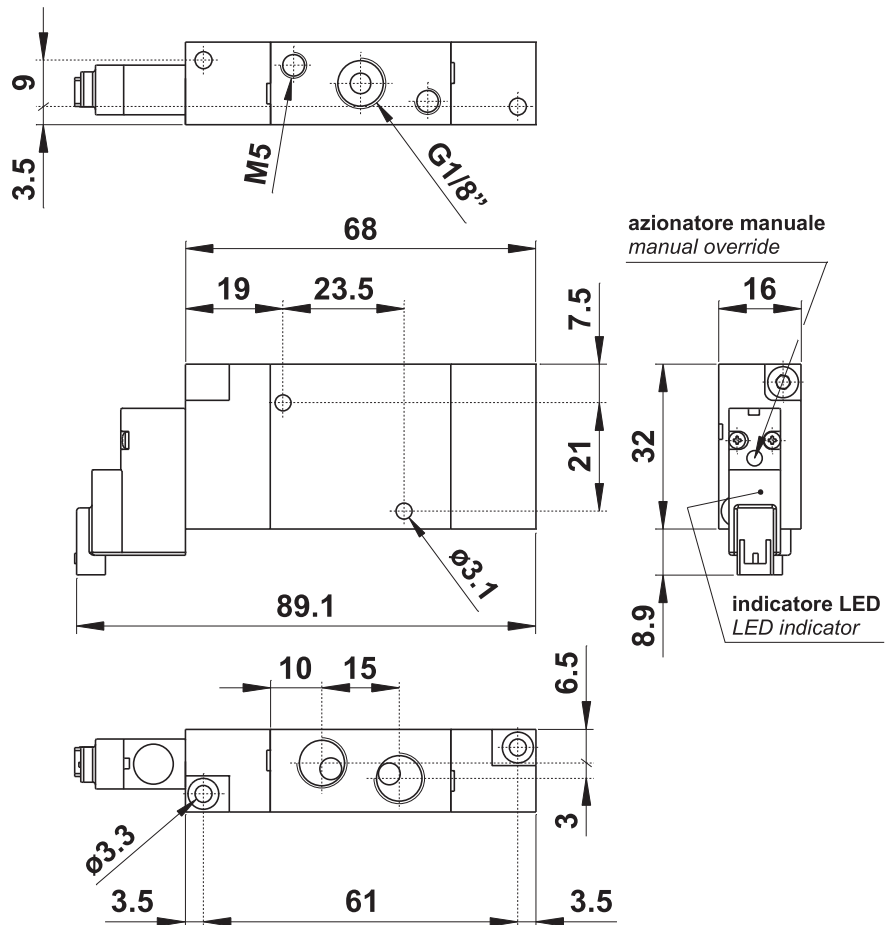
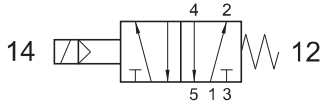

451P EE

5/2 1/8" doppio comando elettrico
5/2 1/8" double solenoid pilot

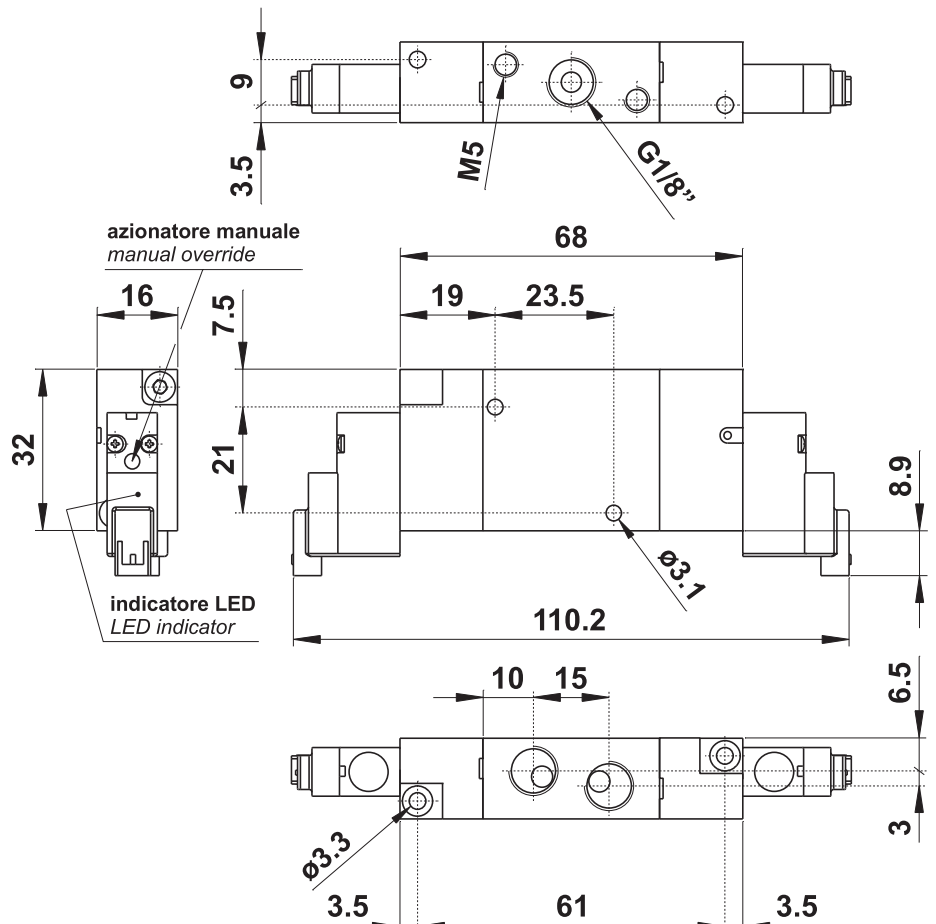
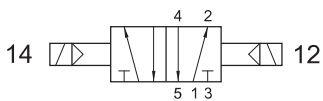

451P CE

5/2 1/8" comando elettrico - ritorno a comando pneumatico

5/2 1/8" solenoid pilot - separate pneumatically piloted return

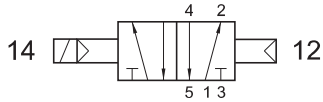

Queste valvole non possono essere utilizzate per installazione singola in linea, ma solo su sottobase.

These valves cannot be installed in-line stand alone, but only on sub-base.

451P ME AS

5/2 1/8" comando elettrico alimentazione separata - ritorno a molla

5/2 1/8" solenoid pilot with separate air supply - spring return

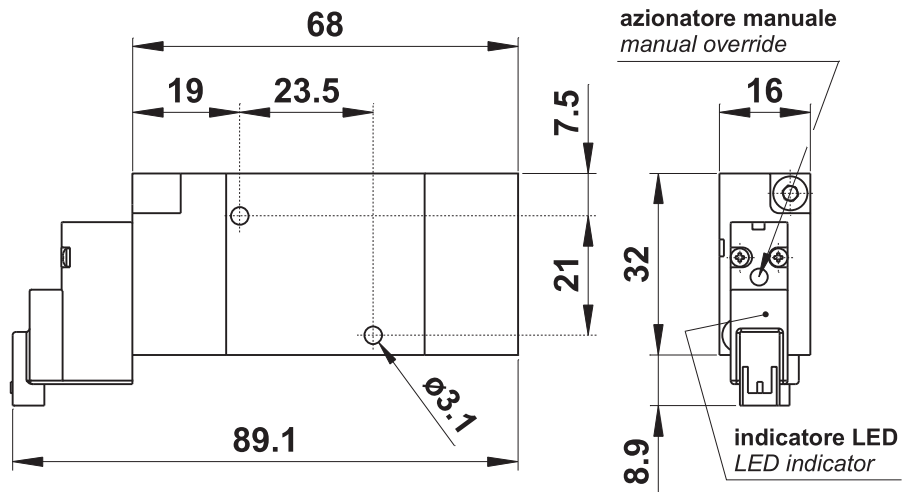
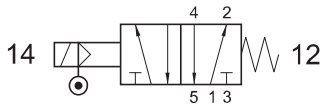

451P EE AS

5/2 1/8" doppio comando elettrico alimentazione separata

5/2 1/8" double solenoid pilot with separate air supply

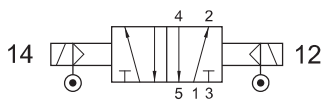

Questa valvola non può essere utilizzata per installazione singola in linea, ma solo su sottobase.

This valve cannot be installed in-line stand alone, but only on sub-base.

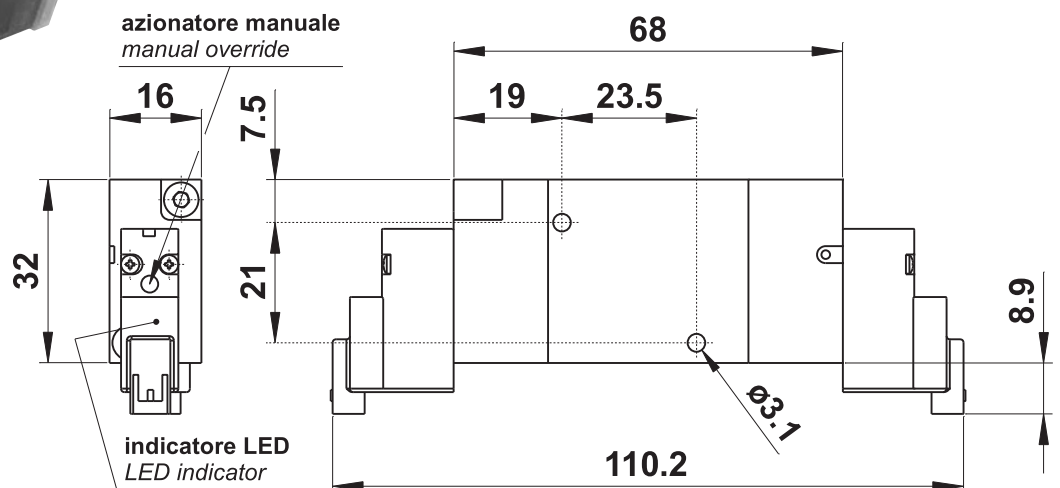

multiconnessione plug-in compatta

compact plug-in multiconnection

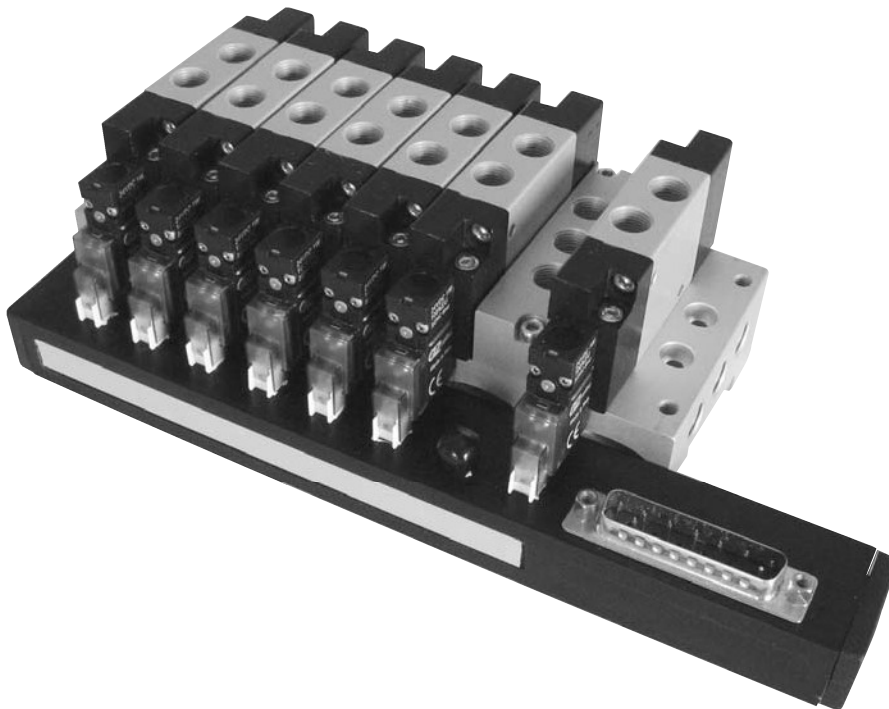
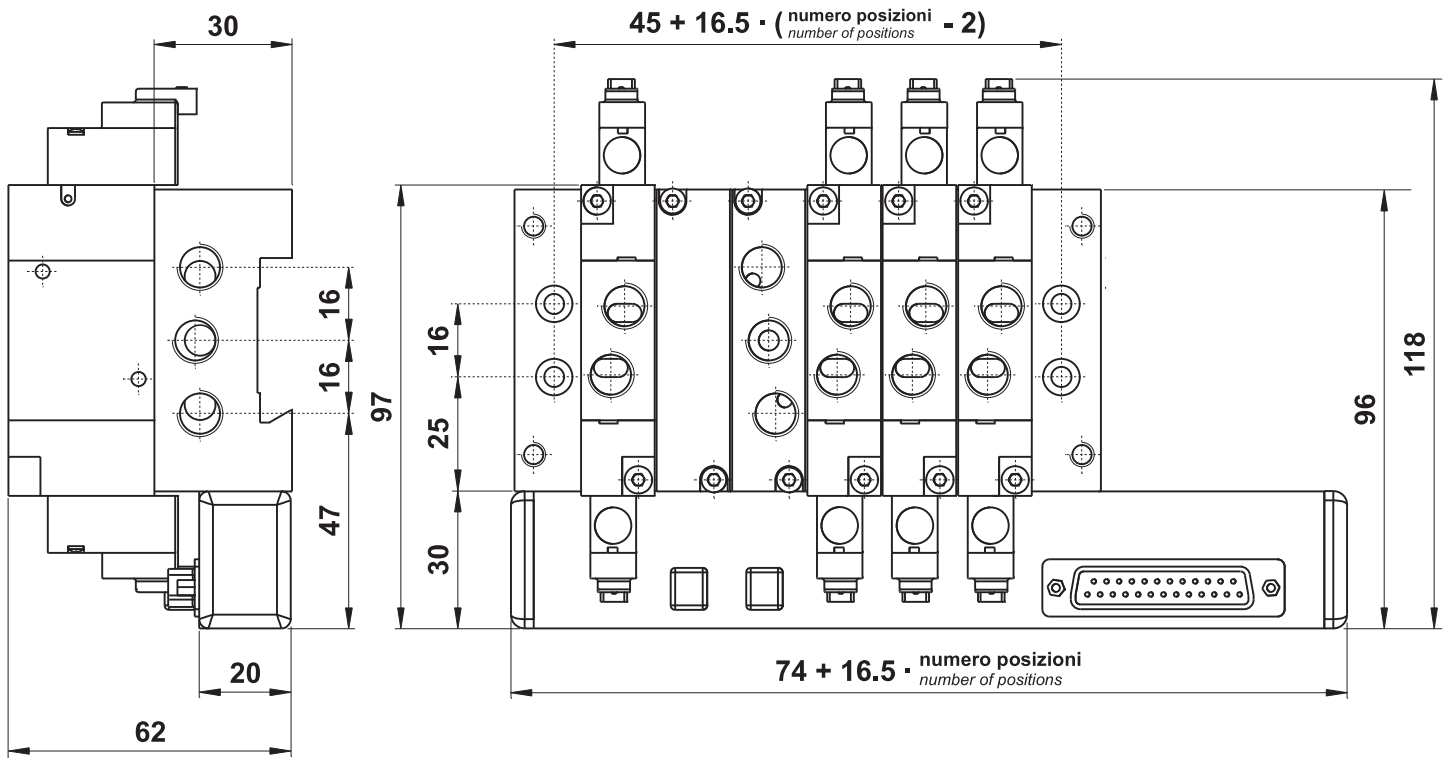

installazione delle valvole

valves installation

basi modulari
multiple sub-bases

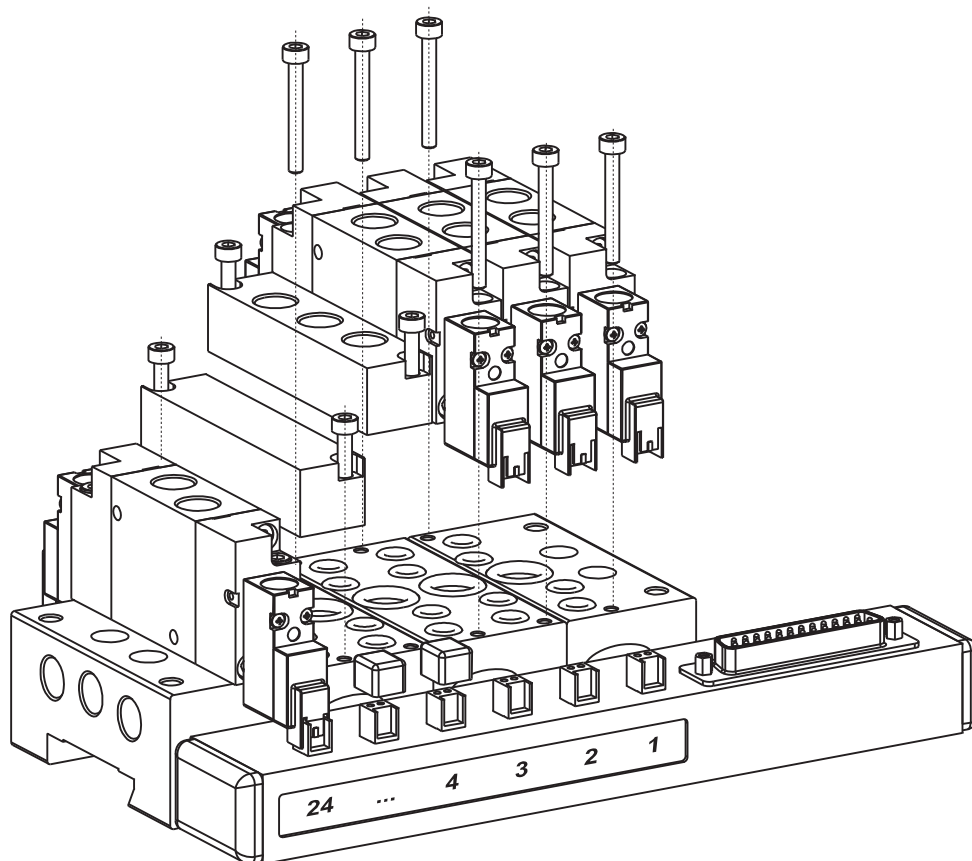
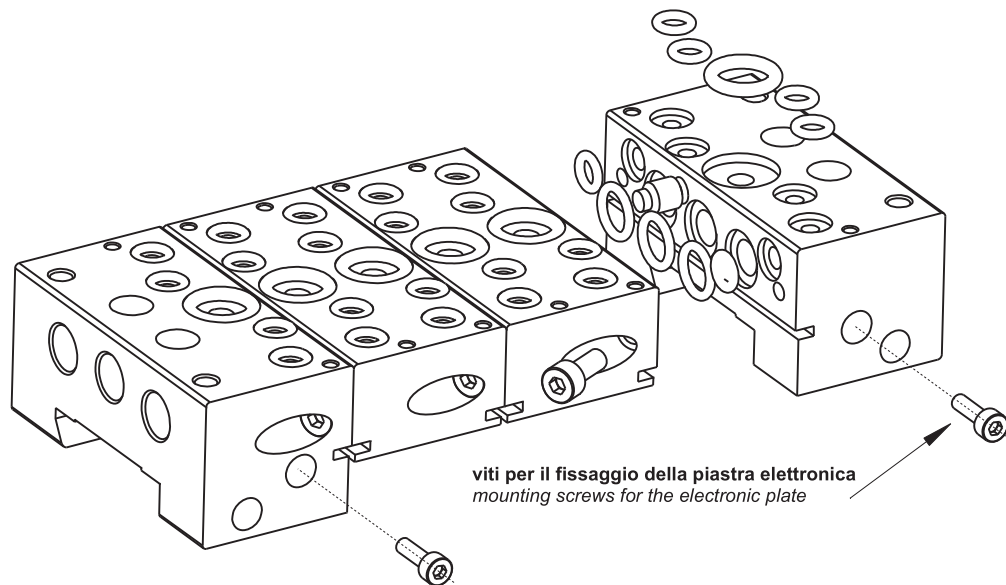

multiconnessione plug-in compatta

compact plug-in multiconnection



fissaggio delle sottobasi su barra omega

manifold mounting on omega-profile

basi modulari

multiple sub-bases

	G1/8"	G1/4"
K	22.5	26
Q	33	33

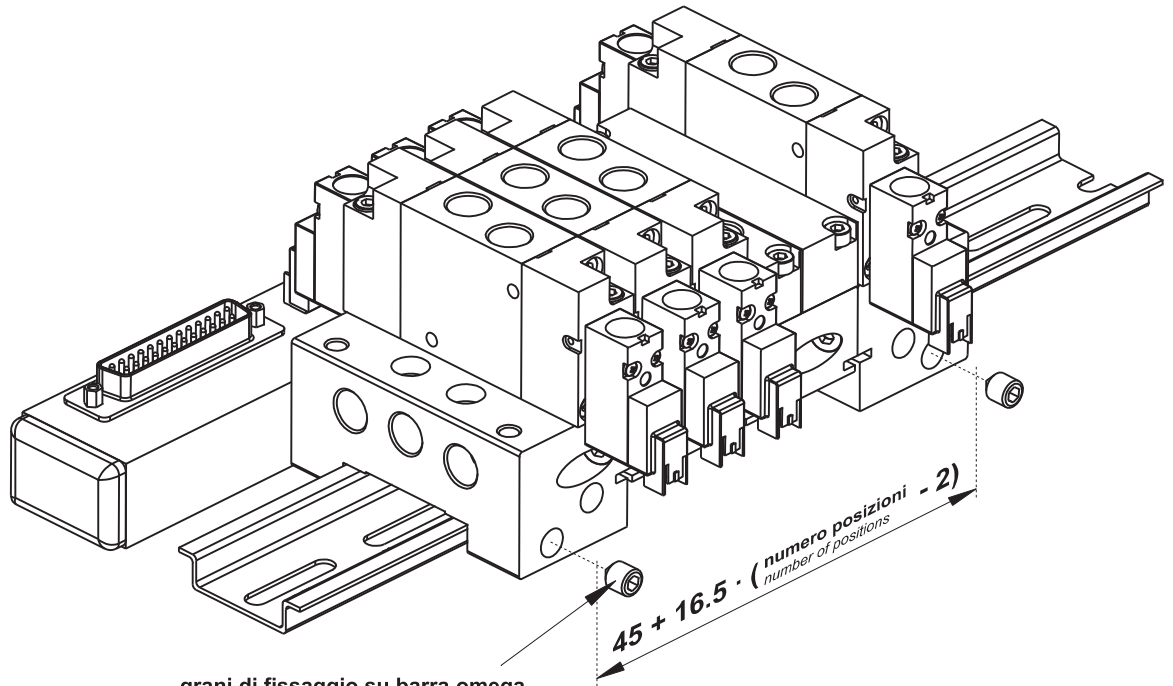

grani di fissaggio su barra omega
mounting nuts for omega-profile

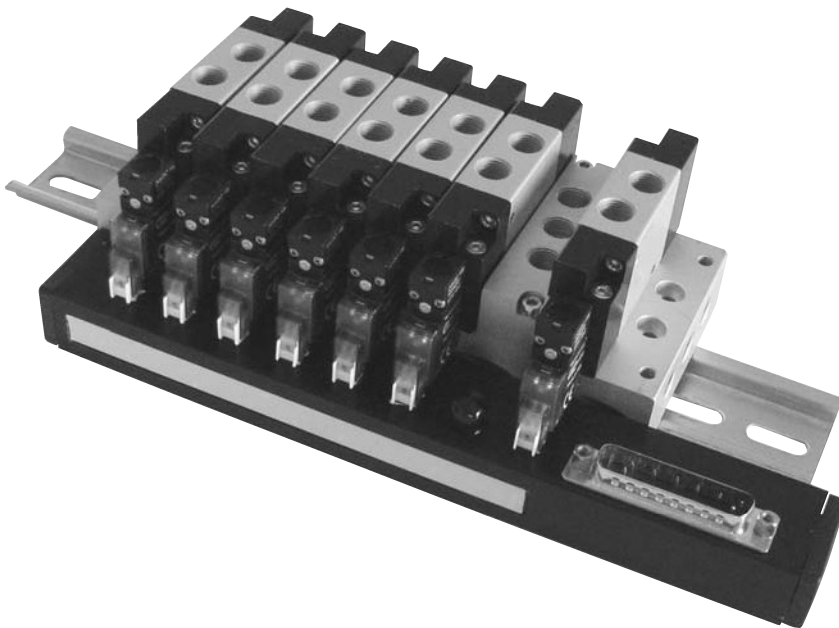

multiconnessione plug-in compatta

compact plug-in multiconnection



connettore D-SUB (DB-25)

connector D-SUB (DB-25)

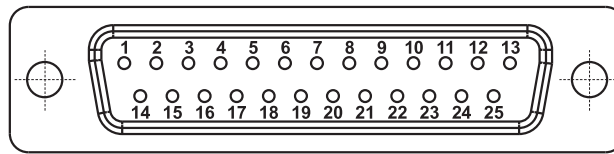

1-24 segnali per elettropiloti
signals for solenoid valves

25 comune (-)
common (-)

 **diaframma interno per separare scarichi e alimentazione**
internal diaphragm to divide air supply and exhaust

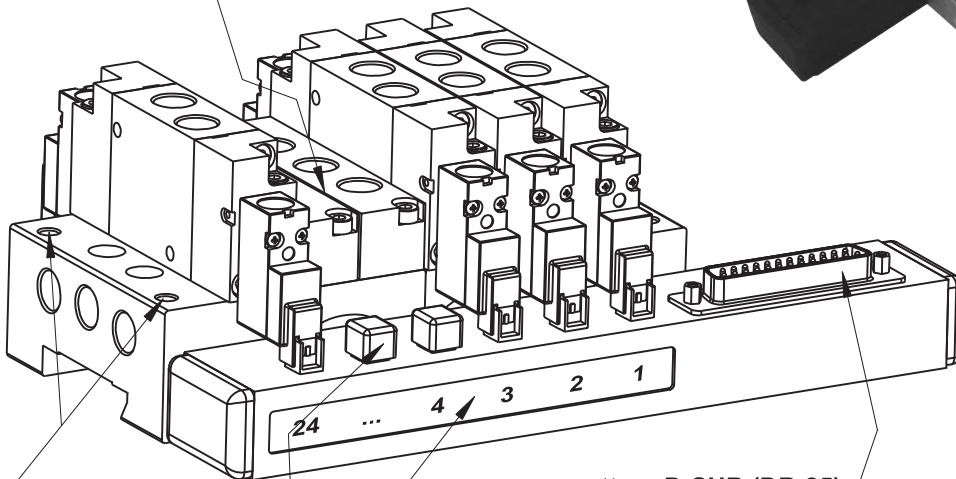
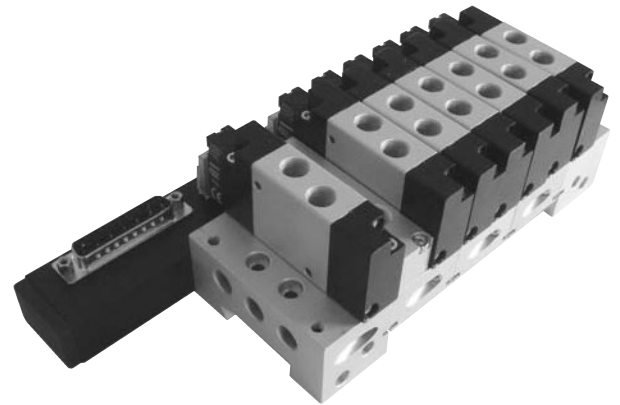

connettore D-SUB (DB-25)
D-SUB connector (DB-25)

alimentazione separata
separate air supply for solenoid

etichetta scrivibile
writable label

protezione per contatto non utilizzato
protection cover for unused contact

diaframma interno internal diaphragm

Questo diaframma deve essere collocato internamente tra un elemento e l'altro della batteria di valvole per interrompere il flusso dell'aria e dividere la batteria in due o più settori. Può essere utilizzato per interrompere solo l'alimentazione, solo gli scarichi o sia l'alimentazione sia gli scarichi. Può essere ordinato singolarmente, e in questo caso deve essere inserito manualmente smontando parzialmente la batteria di valvole, oppure può essere ordinato insieme alla batteria di valvole indicandolo opportunamente come specificato nella chiave di codifica della multiconnessione.

This diaphragm must be inserted between two elements of the manifold to interrupt the air flow and divide the manifold into two or more parts. It can be used to interrupt only the supply air flow, only the exhausts or both air supply and exhausts. It can be ordered as spare part, and in this case it must be manually inserted after having partly disassembled the manifold, or it can be ordered together with the valve manifold, indicating it in the order code as specified in the codes explanation of the multiconnection.

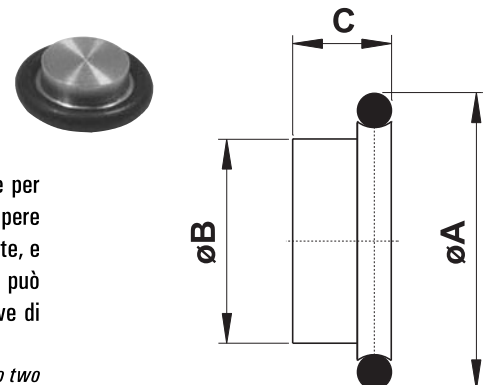

	1/8"
A	10
B	6.6
C	3.2

CODICE DI ORDINAZIONE - ORDER CODE

07.011.2 per batterie di valvole 1/8" - for 1/8" manifolds

multiconnessione plug-in compatta

compact plug-in multiconnection



sottobase modulare modular sub-base



Ogni sottobase è venduta con i particolari necessari per il fissaggio e il montaggio delle valvole. Su ogni sottobase sono disponibili due posizioni. Se è necessario montare una sola valvola, occorre chiudere la posizione rimanente con la piastrina di chiusura.

Each sub-base is sold with all necessary components to install the valves. Each sub-base has two positions. To install only one valve, it is necessary to close the other position with a blanking plate.

CODICE DI ORDINAZIONE - ORDER CODE

07.076.2 per valvole 1/8" - for 1/8" valves

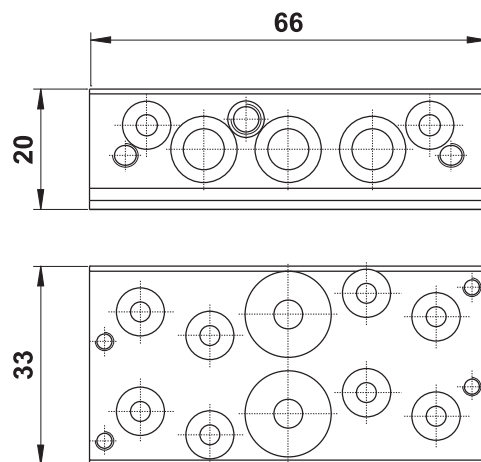

intermedio intermediate header



L'intermedio è utilizzabile per dividere una batteria di valvole in due parti e immettere l'aria per l'alimentazione di una delle due attraverso le connessioni di cui è dotato. È venduto con i pezzi necessari al suo assemblaggio.

An intermediate header with separate air supply is available to be installed in a manifold system which requires mixed operating pressures.

CODICE DI ORDINAZIONE - ORDER CODE

07.077.2 per batterie di valvole 1/8" - for 1/8" manifolds

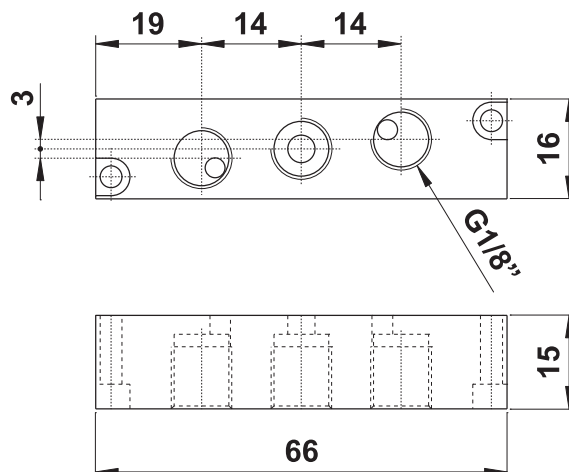

piastrina di chiusura blanking plate



Venduta completa di viti, chiude i fori di sottobasi eventualmente non utilizzate.

CODICE DI ORDINAZIONE - ORDER CODE

07.078.2 per sottobasi 1/8" - for 1/8" sub-bases

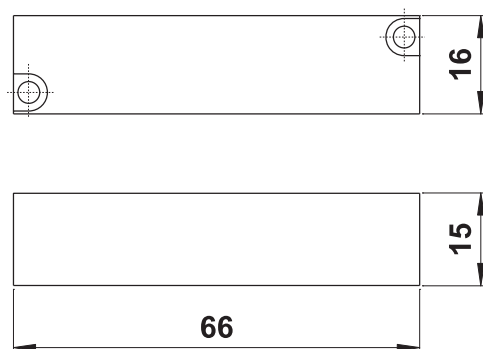

multiconnessione plug-in compatta

compact plug-in multiconnection



terminale destro right inlet header

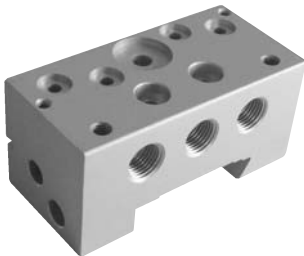

Per ogni batteria di valvole è necessario l'utilizzo di due terminali, uno destro e uno sinistro. Il terminale comprende una posizione per il montaggio di una valvola. Ogni terminale è venduto con i particolari necessari al suo assemblaggio.

Each manifold assembly requires a right and a left hand inlet header kit. The header includes one position for the installation of one valve.

Each inlet header is sold with all necessary components.

CODICE DI ORDINAZIONE

ORDER CODE

07.079.2 terminale destro per sottobasi 1/8"
right hand header for 1/8" manifolds

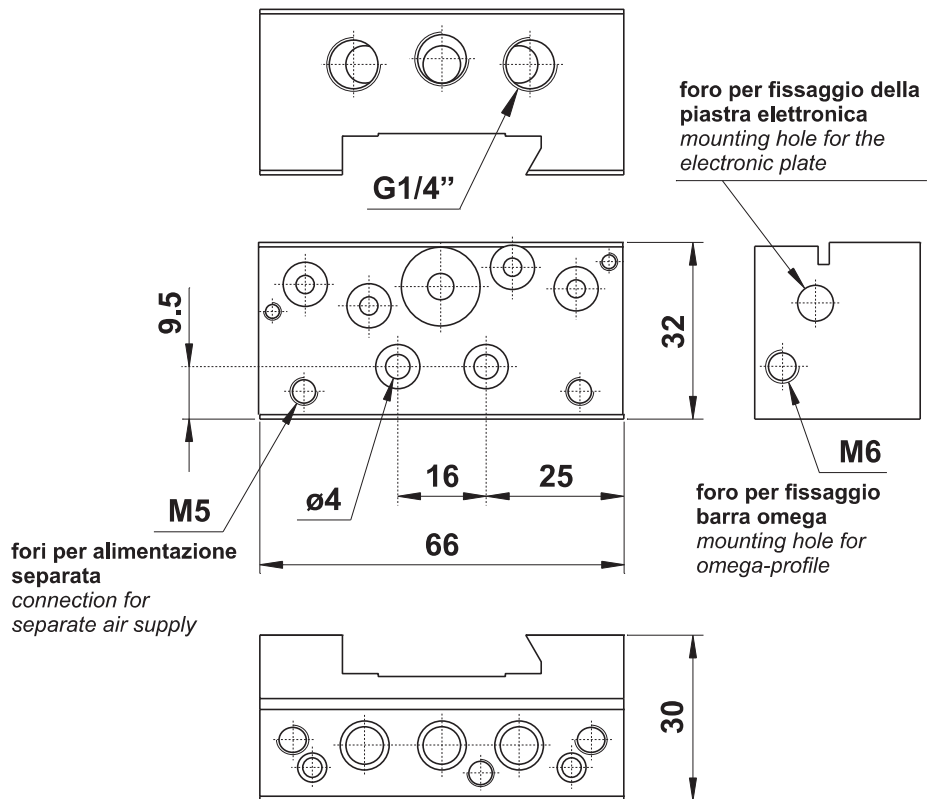

terminale sinistro left inlet header

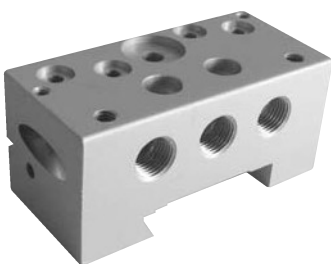

Per ogni batteria di valvole è necessario l'utilizzo di due terminali, uno destro e uno sinistro. Il terminale comprende una posizione per il montaggio di una valvola. Ogni terminale è venduto con i particolari necessari al suo assemblaggio.

Each manifold assembly requires a right and a left hand inlet header kit. The header includes one position for the installation of one valve.

Each inlet header is sold with all necessary components.

CODICE DI ORDINAZIONE

ORDER CODE

07.080.2 terminale sinistro per sottobasi 1/8"
left hand header for 1/8" manifolds

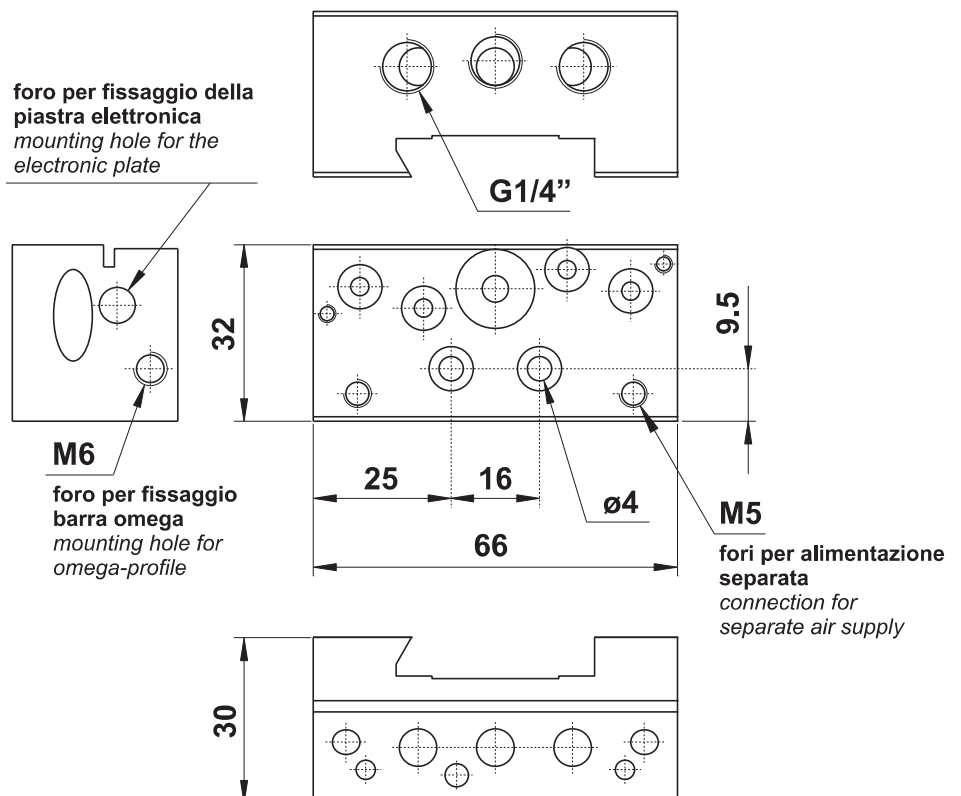

multiconnessione plug-in compatta

compact plug-in multiconnection



piastra elettronica

electronic plate (rack)

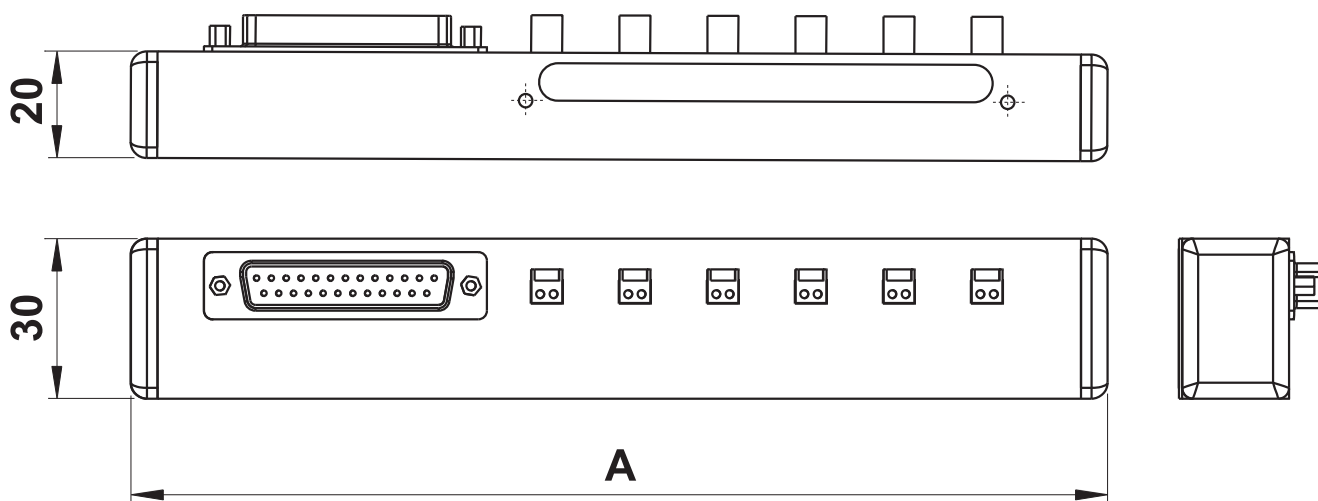

modello model	nr. posiz. no. stations	A
07.082.2	2	107
07.083.2	4	140
07.084.2	6	173
07.085.2	8	206
07.086.2	10	239
07.087.2	12	272

La piastra elettronica è normalmente venduta insieme alla multiconnessione già configurata ma può essere acquistata anche separatamente. I cavi, contenuti all'interno della piastra, sono già preassemblati.

The electronic plate is normally sold together with the already configured multiconnection, but it can be sold also separately. The cables are already assembled inside the plate.



ACCESSORI - ACCESSORIES

- 07.125.0 Cavo 3 metri con connettore D-SUB 25 - 3 metres cable with connector D-SUB 25
- 07.126.0 Cavo 5 metri con connettore D-SUB 25 - 5 metres cable with connector D-SUB 25
- 07.127.0 Cavo 10 metri con connettore D-SUB 25 - 10 metres cable with connector D-SUB 25



multiconnessione plug-in

plug-in multiconnection



- Valvole a spola: doppia 3/2, 5/2 e 5/3 con attacchi filettati G1/8" e G1/4"
Double 3/2, 5/2 and 5/3 spool valves with G1/8" and G1/4" threaded ports
- Comandi elettrici con azionamento manuale
Solenoid pilots with manual override
- Tensione 24V DC
Tension 24V DC
- Protezione elettrica IP 40
Electrical protection IP 40
- Potenza 0.5 ... 1W
Power 0.5 ... 1W
- Massimo 12 valvole bistabili o 24 monostabili (su base a posti fissi in ogni caso 12 valvole al massimo)
Maximum 12 bi-stable valves or 24 mono-stable (on fixed manifold in any case maximum 12 valves)

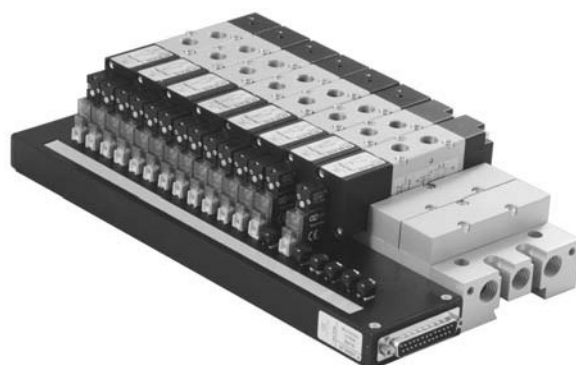

Materiali

Corpo: alluminio 11S

Fondelli: tecnopolimero (*) o alluminio

Molle: INOX

Guarnizioni: NBR

Spola: alluminio nichelato

Parti interne: ottone OT58

Materials

Body: aluminium 11S

End caps: technopolymer (*) or aluminium

Springs: stainless steel

Seals: NBR

Spool: nickel plated aluminium

Internal parts: brass OT58

(*) Le parti in tecnopolimero recano impresso il logo

(*) The parts in technopolymer are marked with the logo

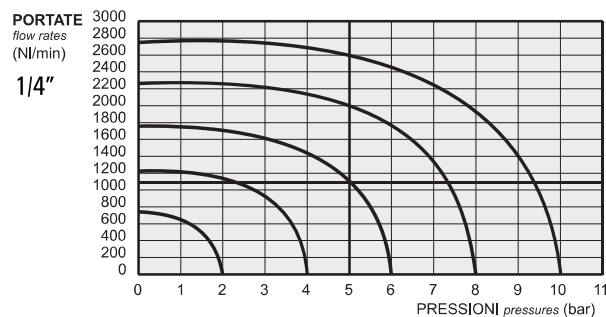
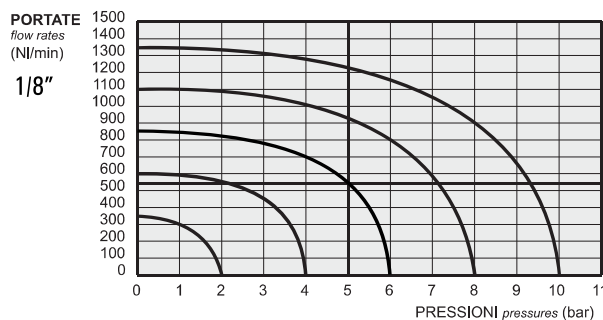

Diametro nominale <i>Nominal orifice</i>		1/8": 5 mm 1/4": 7.5 mm	
Temperatura di esercizio <i>Temperature range</i>		-5 ... +60°C	
Pressione di esercizio <i>Working pressure</i>	al. interna monost. [monost. internal air supply]	al. interna bist. [bi-stable internal air supply]	alim. separata [separate air supply]
	2.5 ... 7 bar 0.25 ... 0.7 MPa	2.5 ... 7 bar 0.25 ... 0.7 MPa	-0.9 ... 10 bar -0.09 ... 1 MPa
Pressione di azionamento (per alimentazione separata) <i>Actuating pressure (for separate air supply)</i>		monostabile [mono-stable]	bistabile [bi-stable]
		2.5 ... 7 bar 0.25 ... 0.7 MPa	2.5 ... 7 bar 0.25 ... 0.7 MPa
Fluido <i>Fluid</i>		Aria filtrata 5µ con o senza lubrificazione <i>5µ filtered, lubricated or non lubricated air</i>	

multiconnessione plug-in

plug-in multiconnection

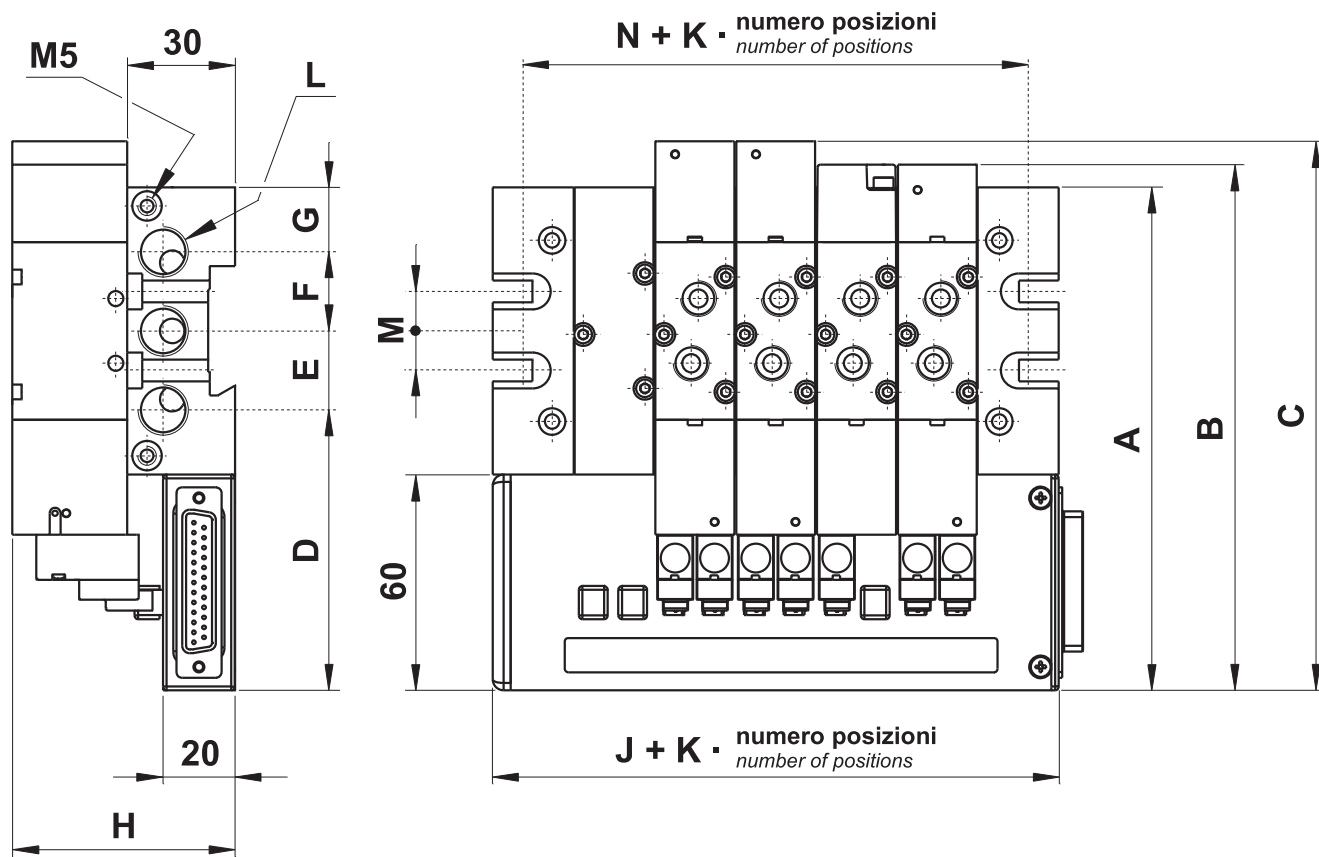

	G1/8"	G1/4"
A	140	155
B	146.5	161.5
C	153	172.5
D	78	81
E	22	26.5
F	22	26.5
G	18	21
H	62	70
J	45	50
K	22.5	26
L	G1/4"	G3/8"
M	22	26.5
N	30	33

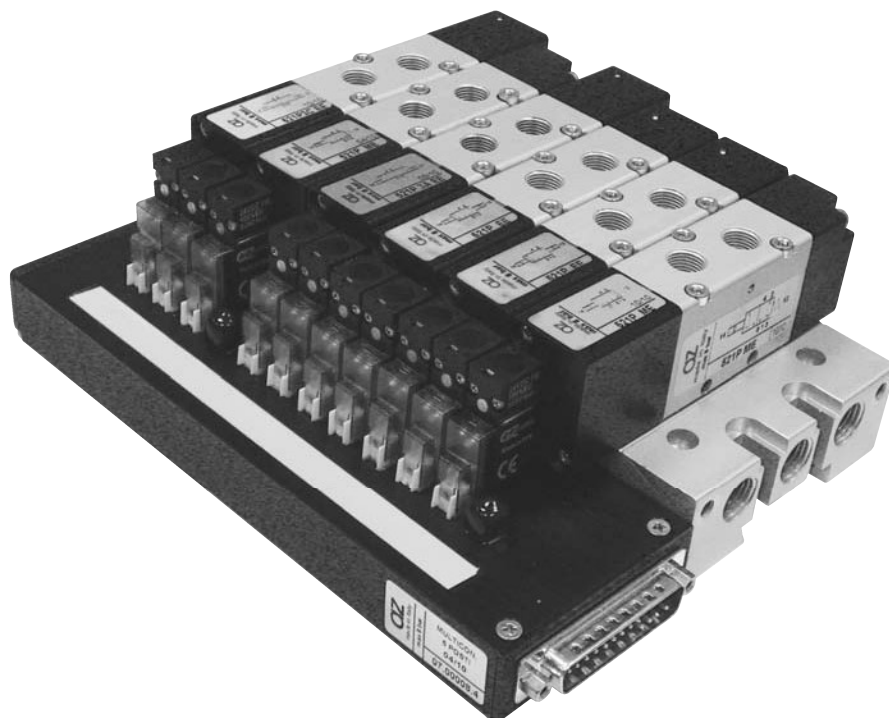

chiave di codifica

key to codes

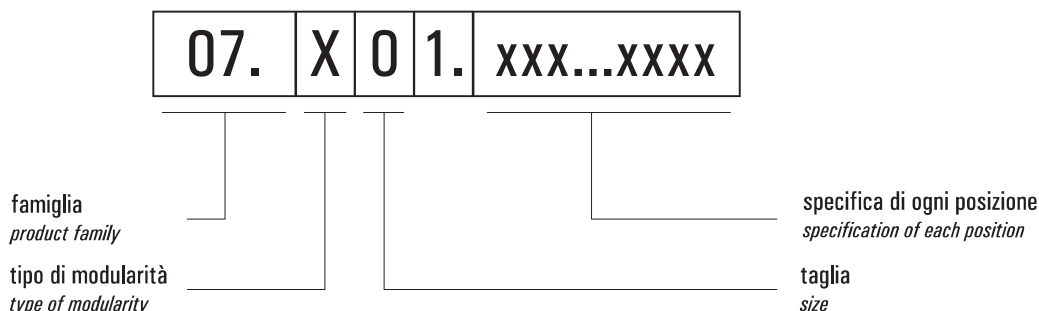

Famiglia [product family]

07 multiconnessione plug-in [plug-in multiconnection]

Tipo di modularità [type of modularity]

X sottobasi a posti fissi [fixed manifold]

Y sottobasi modulari [modular multiple sub-bases]

Taglia [size]

0 G1/8" 22 mm

1 G1/4" 25 mm

2 misto G1/8" + G1/4" [mixed G1/8" + G1/4"]

Specifica di ogni posizione [specification of each position]

RISPETTARE MAIUSCOLE E MINUSCOLE CASE SENSITIVE

G1/8"

a	521P ME
b	521P ME AS
c	521P EE
d	521P EED
e	521P EE AS
f	2x321P ME
g	2x321P ME AS
h	521P3C EE
j	521P3A EE
k	521P3P EE
m	521P3C EE AS
n	521P3A EE AS
p	521P3P EE AS
q	521P CE
r	Piastrina di chiusura [blanking plate]
s	Intermedio [intermediate header]
t	Diaframma alimentazione [diaphragm on air supply]
u	Diaframma scarichi [diaphragm on exhausts]
v	Diaframma alimentazione + scarichi [diaphragm on air supply and exhausts]

G1/4"

A	522P ME
B	522P ME AS
C	522P EE
E	522P EE AS
H	522P3C EE
J	522P3A EE
K	522P3P EE
M	522P3C EE AS
N	522P3A EE AS
P	522P3P EE AS
R	Piastrina di chiusura [blanking plate]
S	Intermedio [intermediate header]
T	Diaframma alimentazione [diaphragm on air supply]
U	Diaframma scarichi [diaphragm on exhausts]
V	Diaframma alimentazione + scarichi [diaphragm on air supply and exhausts]

Le valvole, le parti elettroniche e le sottobasi con i relativi elementi accessori sono compresi e premontati nella multiconnessione ordinata secondo la presente chiave di codifica, non è pertanto necessario ordinarli separatamente.

Valves, electronic parts and sub-bases with accessories are included and preassembled in the multiconnection manifold ordered according to these codes. It is not necessary to order them separately.

multiconnessione plug-in

plug-in multiconnection



521P ME

5/2 1/8" comando elettrico - ritorno a molla
5/2 1/8" solenoid pilot - spring return

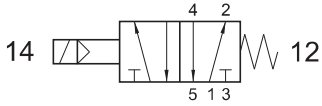

522P ME

5/2 1/4" comando elettrico - ritorno a molla
5/2 1/4" solenoid pilot - spring return

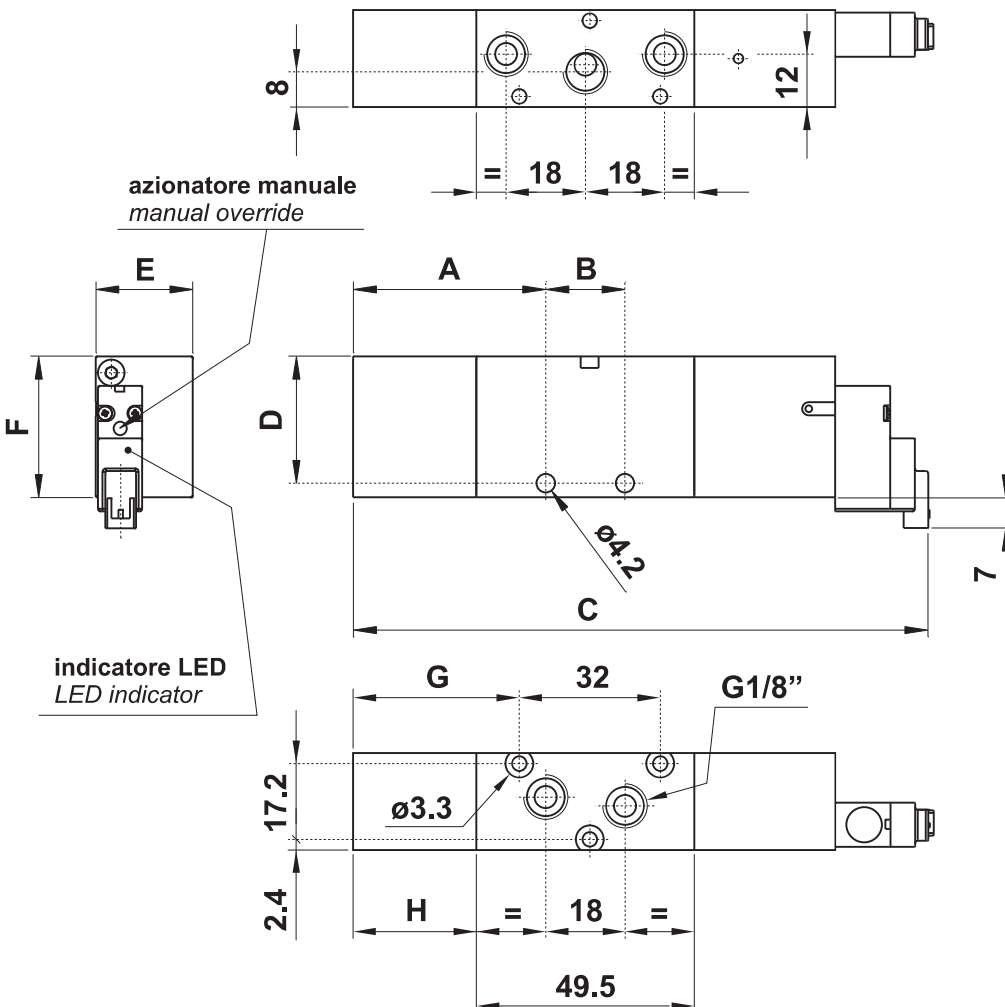
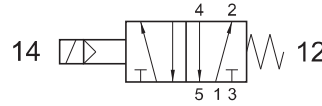

	G1/8"	G1/4"
A	37.25	43
B	18	22
C	124.1	143.1
D	28.8	34.3
E	22	25
F	32	40
G	31.25	32
H	21.5	23

multiconnessione plug-in

plug-in multiconnection



521P ME AS

5/2 1/8" comando elettrico alimentazione separata - ritorno a molla
5/2 1/8" solenoid pilot with separate air supply - spring return

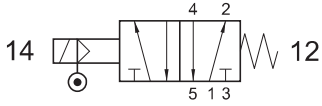

522P ME AS

5/2 1/4" comando elettrico alimentazione separata - ritorno a molla
5/2 1/4" solenoid pilot with separate air supply - spring return

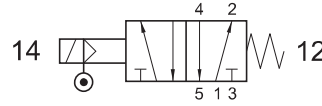

521P CE

5/2 1/8" comando elettrico - ritorno a comando pneumatico
5/2 1/8" solenoid pilot - separate pneumatically piloted return

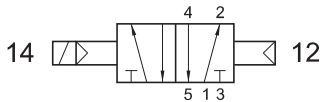

Queste valvole non possono essere utilizzate per installazione singola in linea, ma solo su sottobase.

These valves cannot be installed in-line stand alone, but only on sub-base.

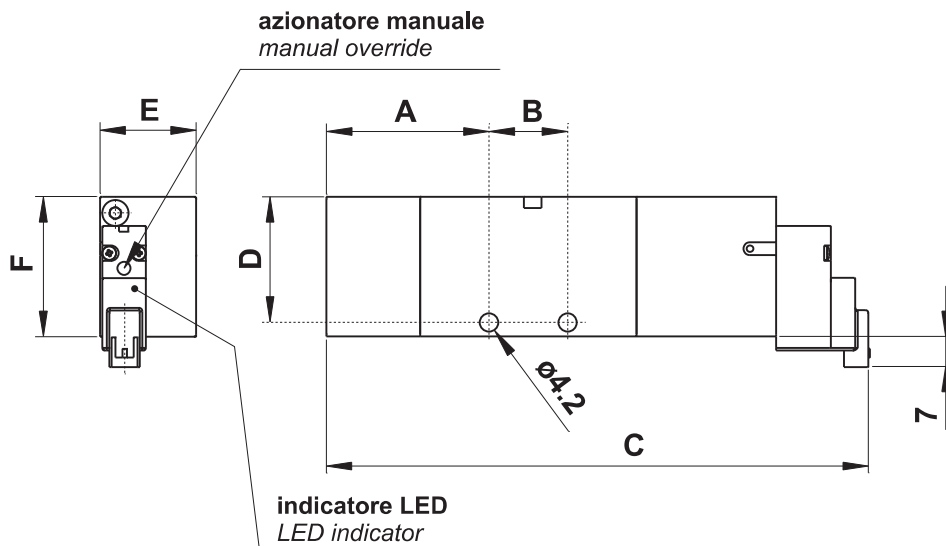

	G1/8"	G1/4"
A	37.25	43
B	18	22
C	124.1	143.1
D	28.8	34.3
E	22	25
F	32	40

multiconnessione plug-in

plug-in multiconnection



521P EE AS

5/2 1/8" doppio comando elettrico alimentazione separata
5/2 1/8" double solenoid pilot with separate air supply

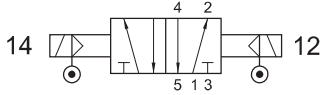

522P EE AS

5/2 1/4" doppio comando elettrico alimentazione separata
5/2 1/4" double solenoid pilot with separate air supply

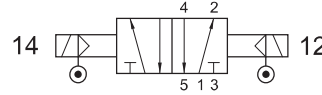

2x321P ME AS

doppia 3/2 1/8" comando elettrico alimentazione separata - ritorno a molla
double 3/2 1/8" solenoid pilot with separate air supply - spring return

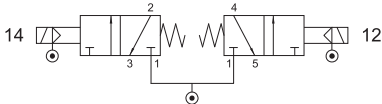

Queste valvole non possono essere utilizzate per installazione singola in linea, ma solo su sottobase.
These valves cannot be installed in-line stand alone, but only on sub-base.

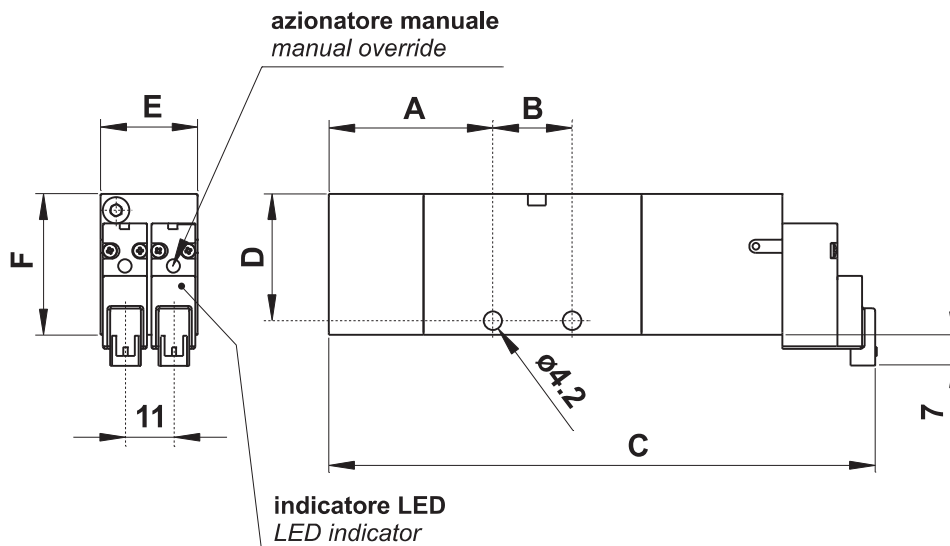

	G1/8"	G1/4"
A	37.25	43
B	18	22
C	124.1	143.1
D	28.8	34.3
E	22	25
F	32	40

multiconnessione plug-in

plug-in multiconnection



521P3C EE

centri chiusi
closed centres

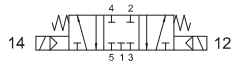

521P3A EE

centri aperti
open centres

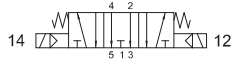

521P3P EE

centri in pressione
pressurized centres

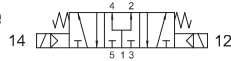

522P3C EE

centri chiusi
closed centres

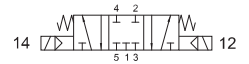

522P3A EE

centri aperti
open centres

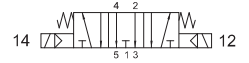

522P3P EE

centri in pressione
pressurized centres

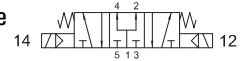

5/3 1/8" doppio comando elettrico

5/3 1/8" double solenoid pilot

5/3 1/4" doppio comando elettrico

5/3 1/4" double solenoid pilot

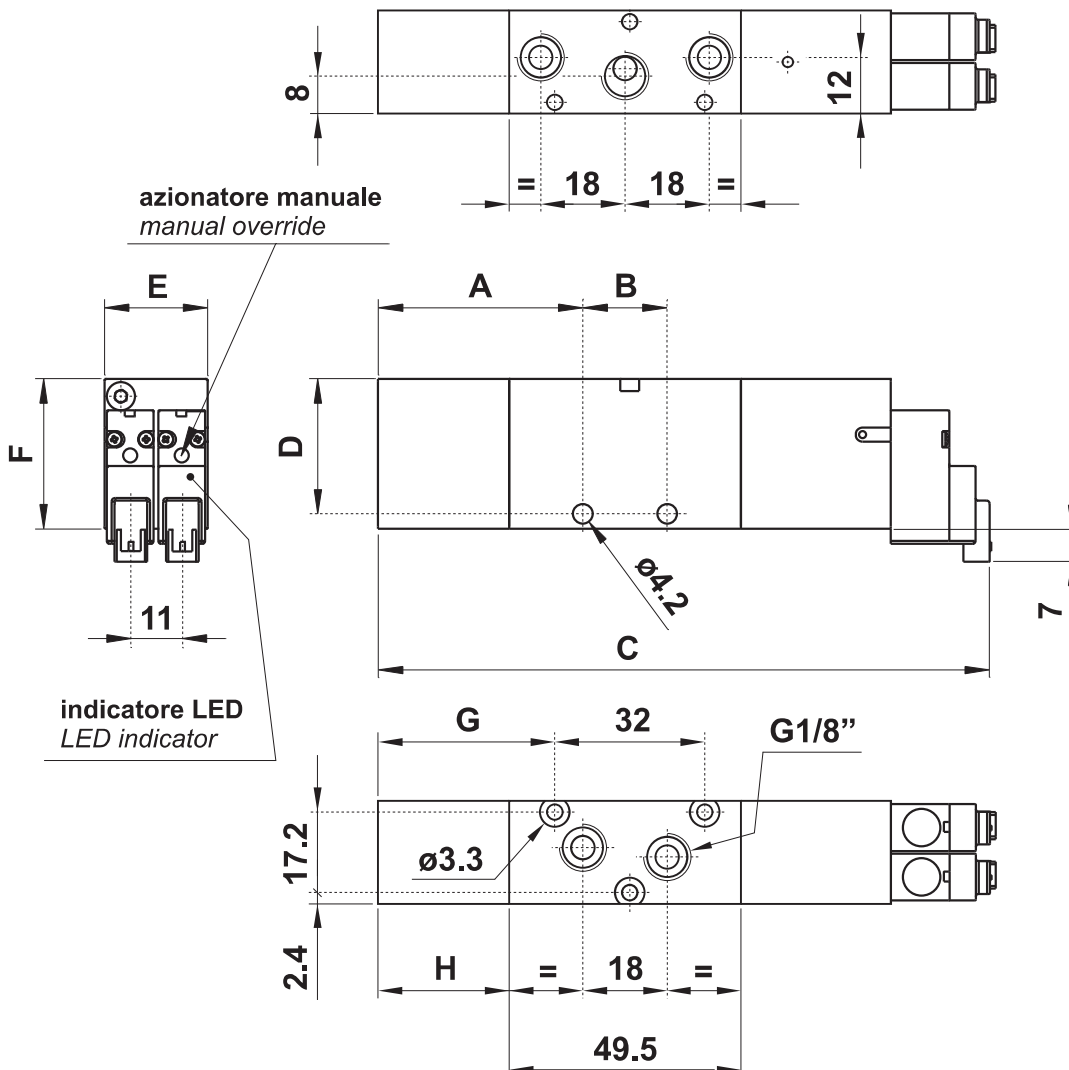

	G1/8"	G1/4"
A	43.75	54
B	18	22
C	130.5	154.2
D	28.8	34.3
E	22	25
F	32	40
G	37.75	43
H	28	34

multiconnessione plug-in

plug-in multiconnection



521P3C EE AS centri chiusi
closed centres

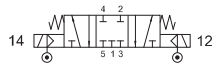

521P3A EE AS centri aperti
open centres

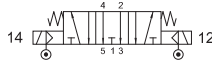

521P3P EE AS centri in pressione
pressurized centres

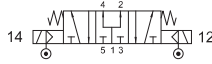

5/3 1/8" doppio comando elettrico alimentazione separata
5/3 1/8" double solenoid pilot with separate air supply

522P3C EE AS centri chiusi
closed centres

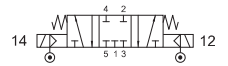

522P3A EE AS centri aperti
open centres

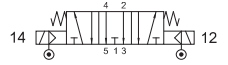

522P3P EE AS centri in pressione
pressurized centres

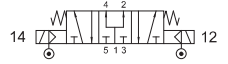

5/3 1/4" doppio comando elettrico alimentazione separata
5/3 1/4" double solenoid pilot with separate air supply

Queste valvole non possono essere utilizzate per installazione singola in linea, ma solo su sottobase.

These valves cannot be installed in-line stand alone, but only on sub-base.

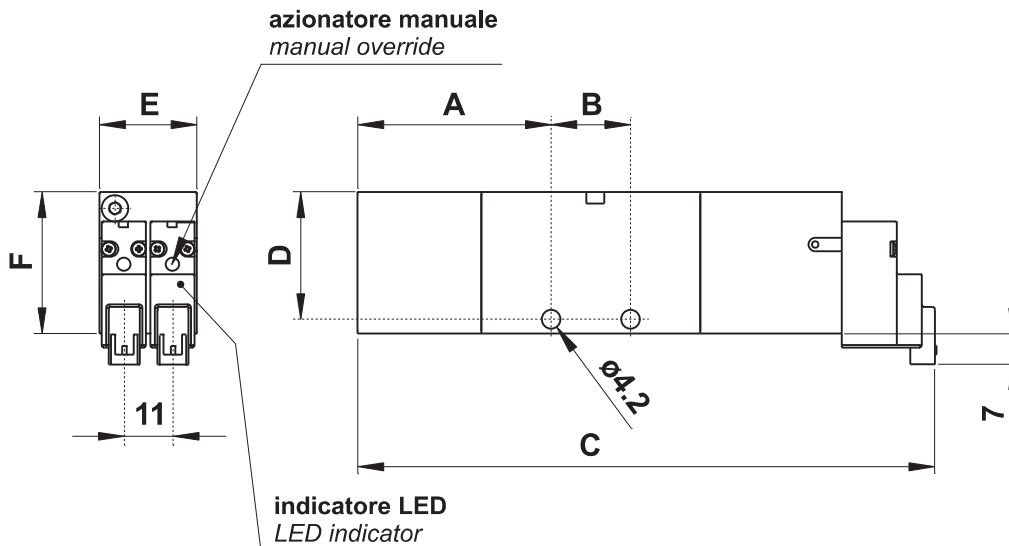

	G1/8"	G1/4"
A	43.75	54
B	18	22
C	130.5	154.2
D	28.8	34.3
E	22	25
F	32	40

installazione delle valvole

valves installation

basi modulari

multiple sub-bases

1

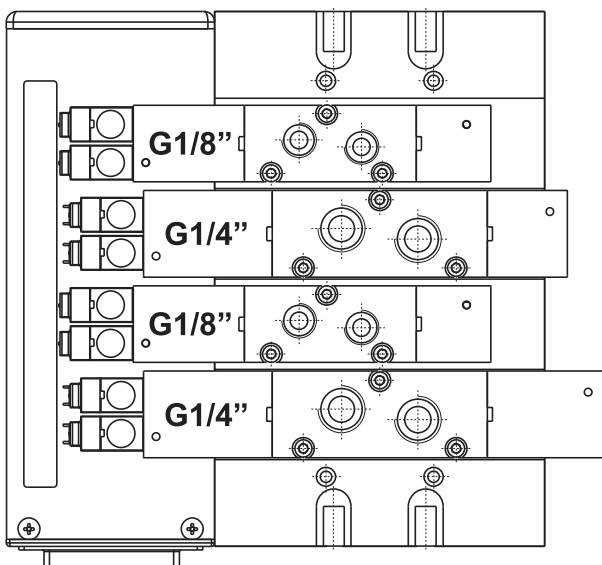
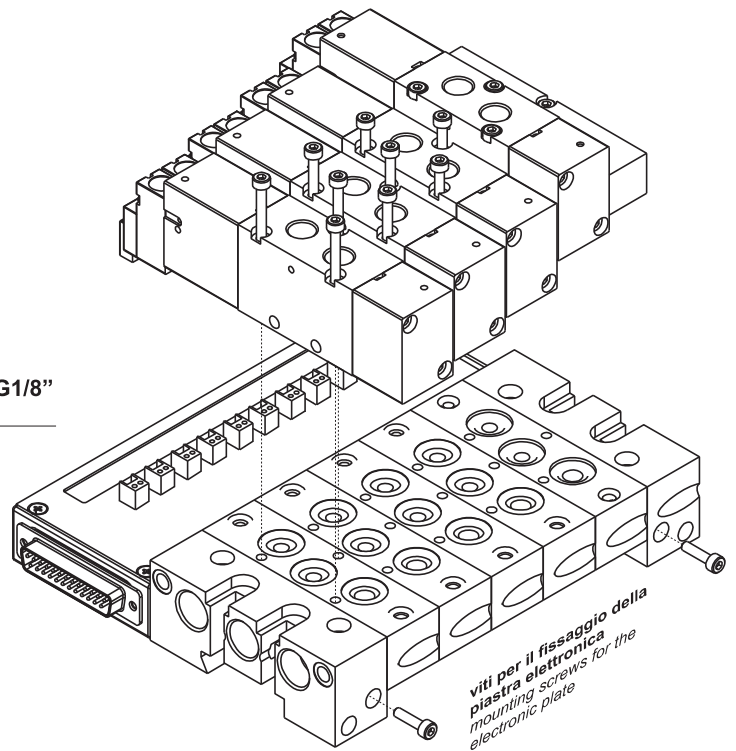
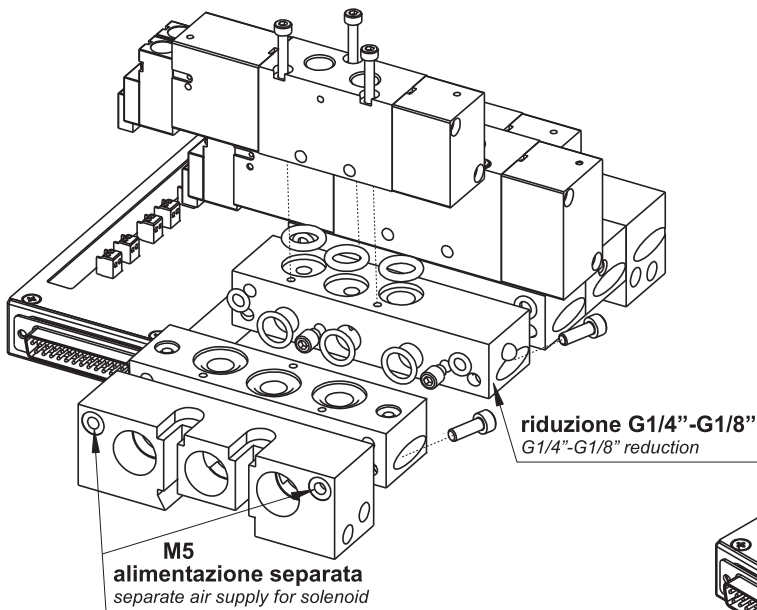
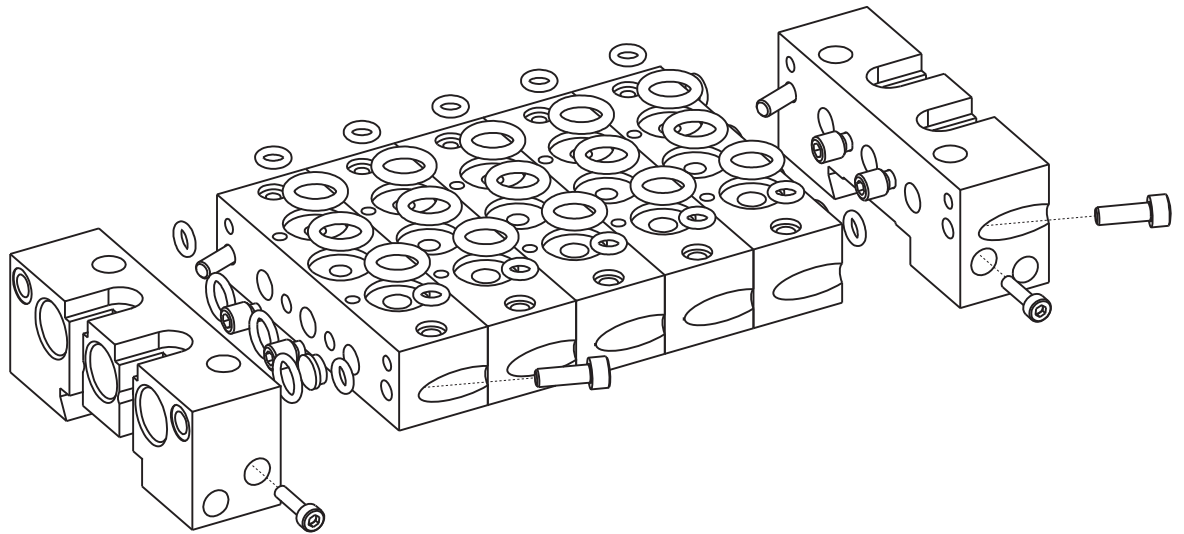

Gli ingombri esterni della multiconnessione ibrida (con valvole da 1/8" e da 1/4") sono identici alla multiconnessione da 1/4". In una multiconnessione ibrida solo le valvole da 1/4" possono avere l'alimentazione separata per l'elettropilota.

The external overall dimensions of a hybrid multiconnection are the same of a 1/4" multiconnection. In a hybrid multiconnection, only 1/4" valves can have separate air supply for the solenoid.

installazione delle valvole

valves installation

basi a posti fissi
fixed manifolds

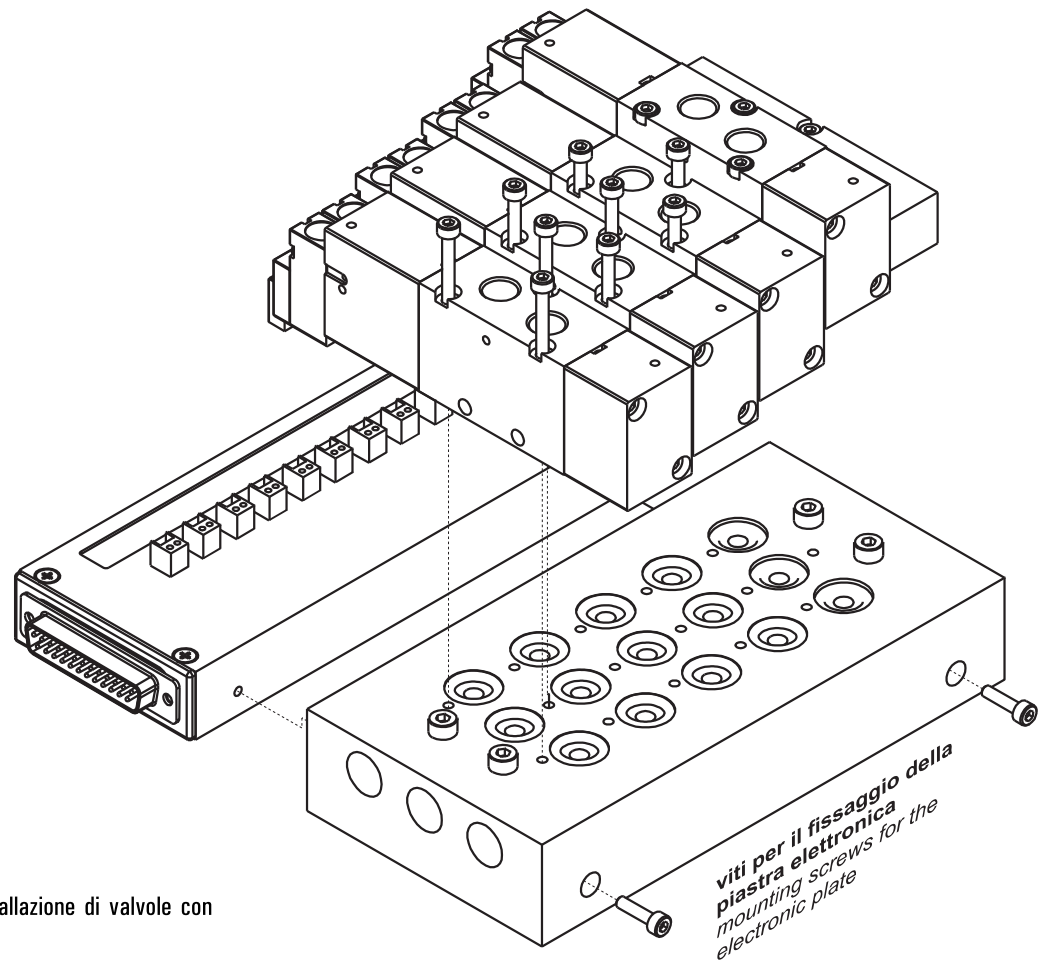

La base a posti fissi non consente l'installazione di valvole con alimentazione separata.

The installation of valves with separate air supply is not possible on fixed manifolds.

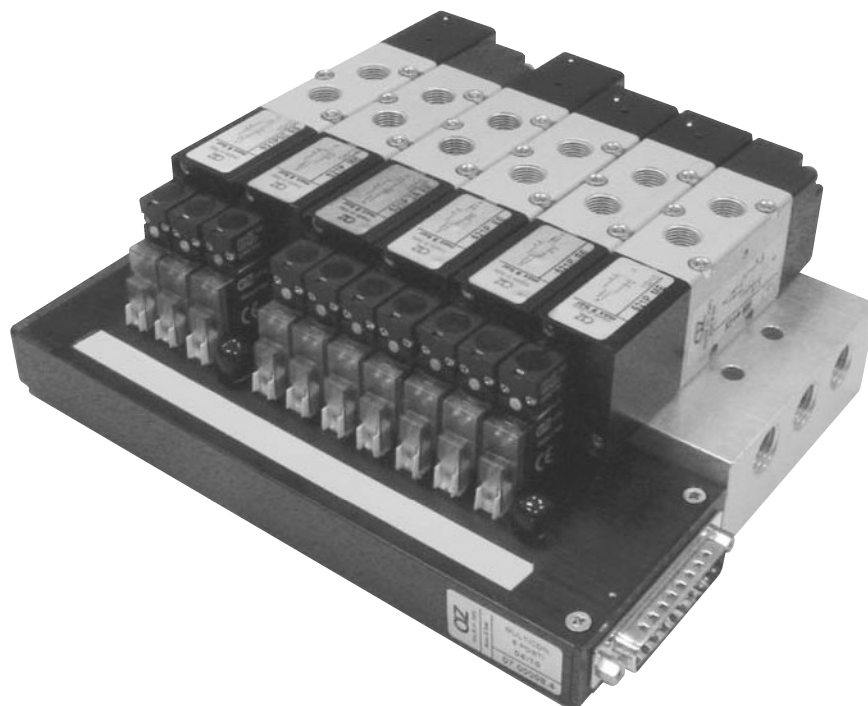

fissaggio delle sottobasi dalla parte superiore

manifold mounting from the top side

basi modulari multiple sub-bases

	G1/8"	G1/4"
K	22.5	26
P	30	33
R	22	26.5

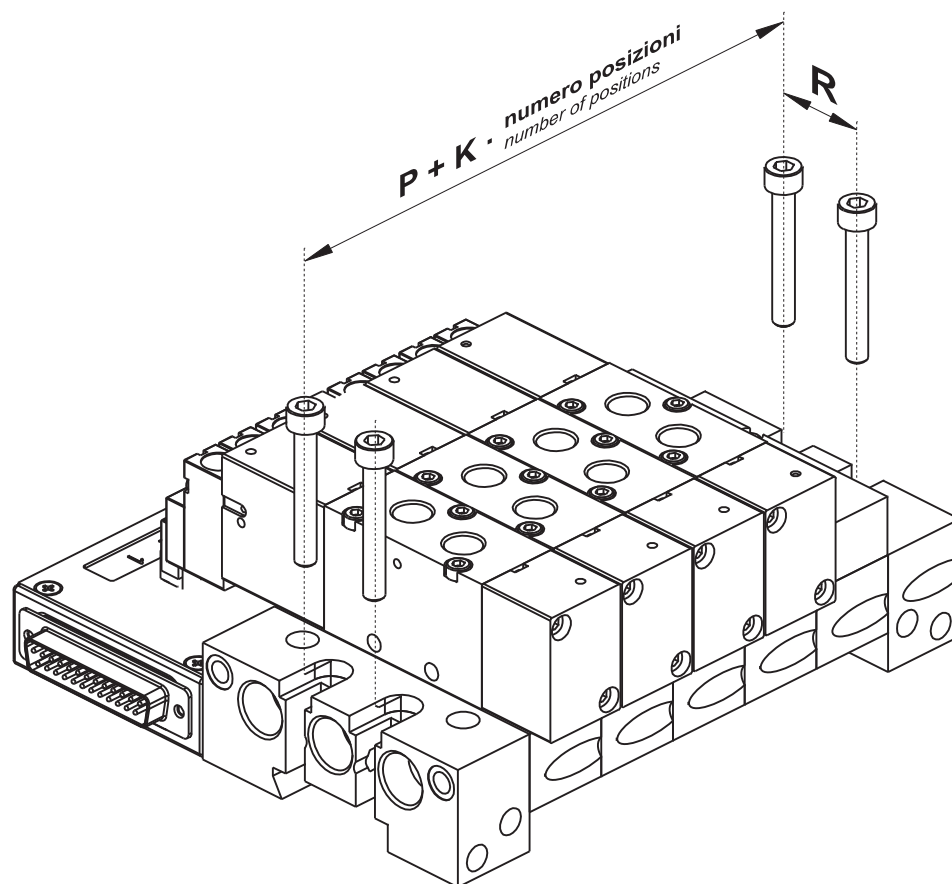

basi a posti fissi fixed manifolds

	G1/8"	G1/4"
K	22.5	26
P	12	10
R	20.5	31

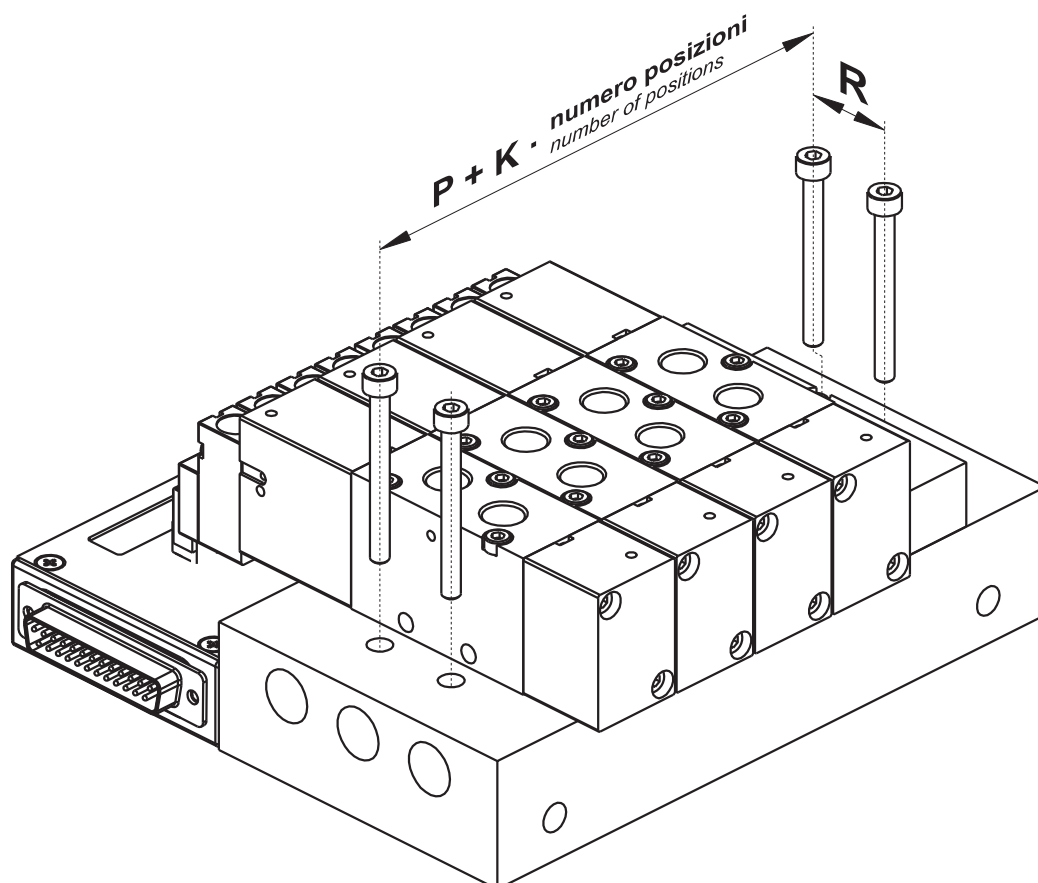

fissaggio delle sottobasi su barra omega

manifold mounting on omega-profile

basi modulari

multiple sub-bases

	G1/8"	G1/4"
K	22.5	26
Q	33	33

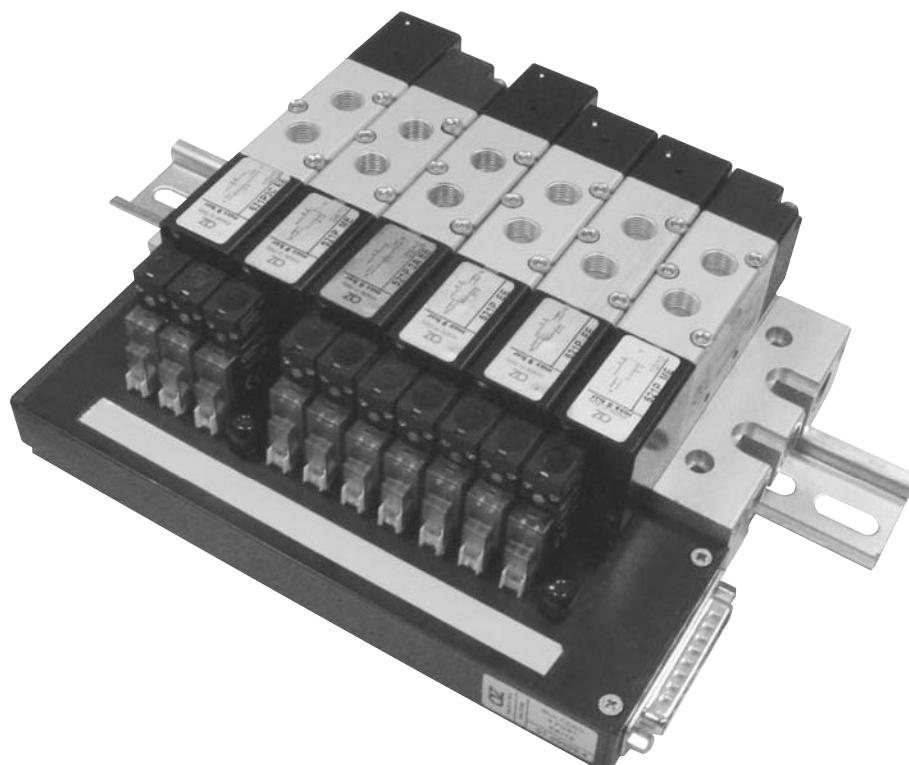
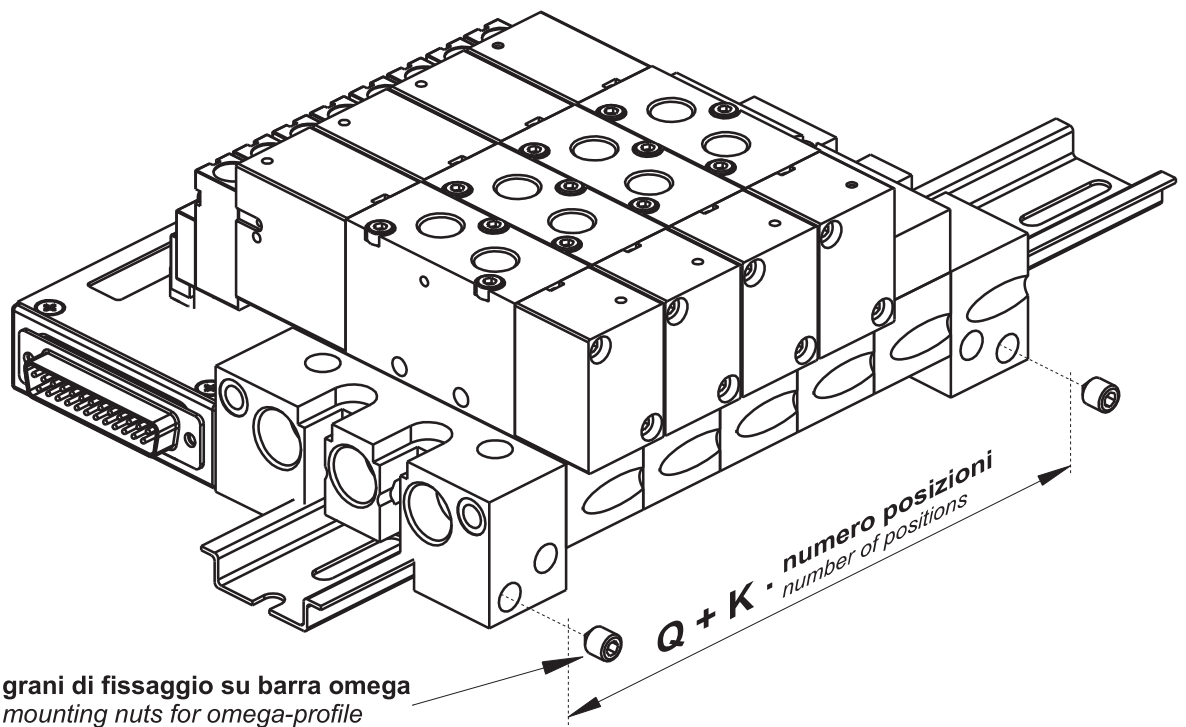

multiconnessione plug-in

plug-in multiconnection





connettore D-SUB (DB-25)

connector D-SUB (DB-25)

1-24 segnali per elettropiloti
signals for solenoid valves

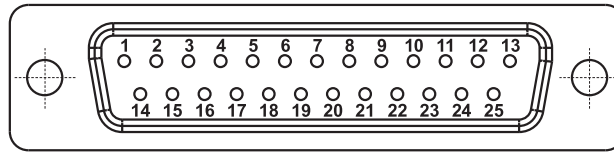
25 comune (-)
common (-)



 **diaframma interno
per separare scarichi
e alimentazione**
internal diaphragm to divide
air supply and exhaust

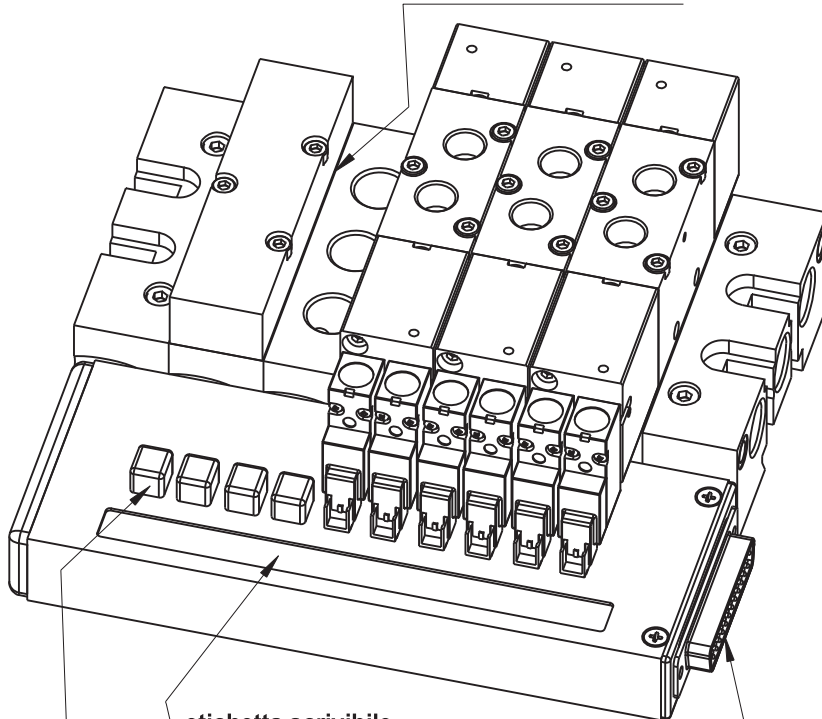

etichetta scrivibile
writable label

**protezione per contatto
non utilizzato**
protection cover for unused contact

connettore D-SUB (DB-25)
D-SUB connector (DB-25)

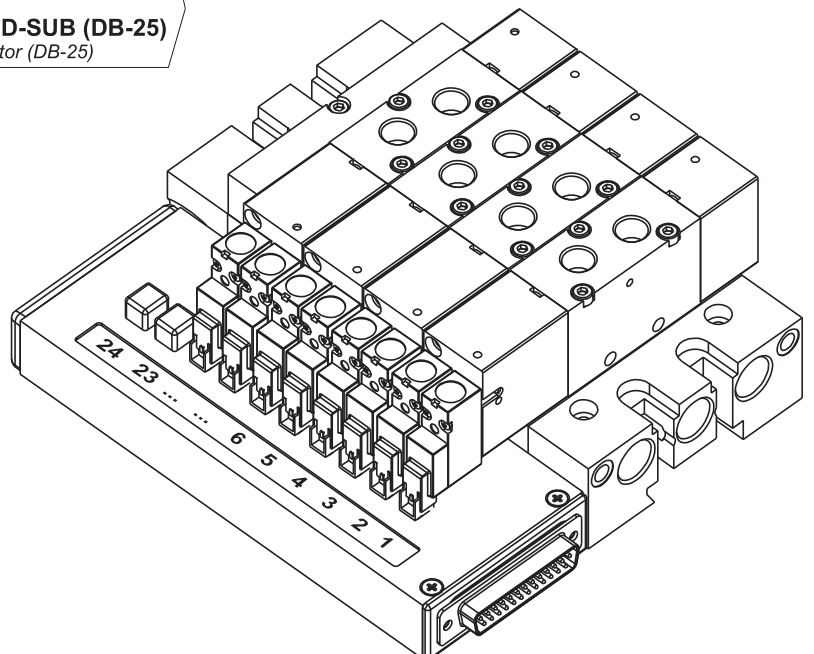

multiconnessione plug-in

plug-in multiconnection



sottobase sub-base



	1/8"	1/8" ATEX	1/4"	1/4" ATEX
A	80	80	95	95
B	22.5	31	26	31

Le sottobasi possono essere utilizzate per il fissaggio di valvole da 1/8" o da 1/4". Ogni sottobase è venduta con i particolari necessari per il fissaggio e il montaggio della valvola.

Each sub-base is sold with all necessary components to install 1/8" or 1/4" valves.

CODICI DI ORDINAZIONE - ORDER CODES

- 07.039.2 per valvole 1/8" - for 1/8" valves
- 07.008.2 per valvole 1/8" ATEX - for 1/8" valves ATEX
- 07.052.2 per valvole 1/4" - for 1/4" valves
- 07.060.2 per valvole 1/4" ATEX - for 1/4" valves ATEX

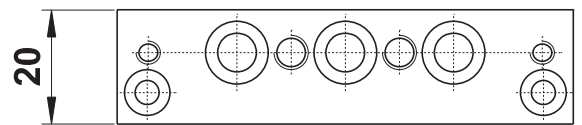
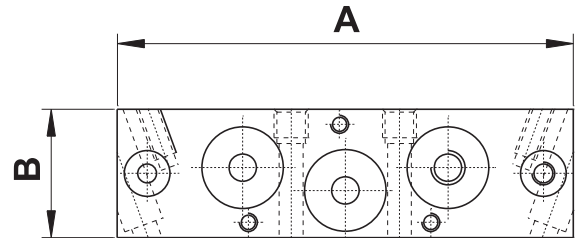

intermedio

intermediate header



L'intermedio è utilizzabile per dividere una batteria di valvole in due parti e immettere l'aria per l'alimentazione di una delle due attraverso le connessioni di cui è dotato, e/o per dividere in due parti gli scarichi convogliati. È venduto con i pezzi necessari al suo assemblaggio.

An intermediate header with separate air supply is available to be installed in a manifold system which requires mixed operating pressures. It can be used also to divide the common exhausts. It is sold with all necessary components for installation.

CODICI DI ORDINAZIONE - ORDER CODES

- 07.040.2 per batterie di valvole 1/8" - for 1/8" manifolds
- 07.053.2 per batterie di valvole 1/4" - for 1/4" manifolds

	1/8"	1/4"
A	19	20
B	80	95
C	21	24
D	22.5	26
E	G1 1/4"	G3/8"
F	21	23

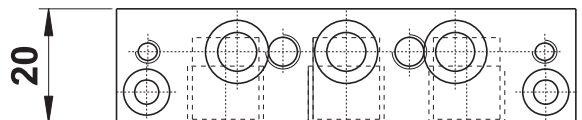
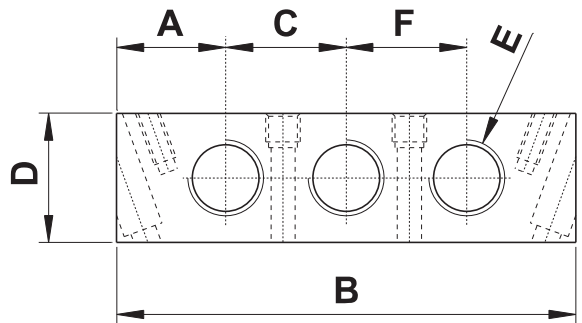

piastrina di chiusura

blanking plate

	1/8"	1/4"
A	80	95
D	22	25

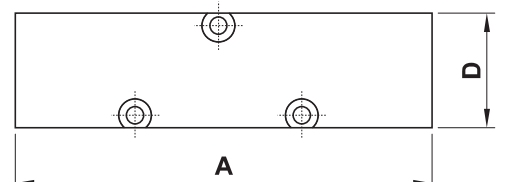
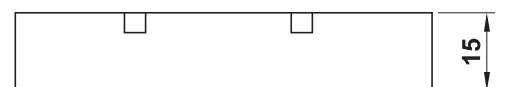

Venduta completa di viti, chiudi i fori di sottobasi eventualmente non utilizzate.

The blanking plate with gasket and screws is available to close manifold stations not in use.

CODICI DI ORDINAZIONE - ORDER CODES

- 00.011.3 per sottobasi 1/8" - for 1/8" sub-bases
- 01.007.3 per sottobasi 1/4" - for 1/4" sub-bases

multiconnessione plug-in

plug-in multiconnection



terminale destro G1/8"

G1/8" right inlet header

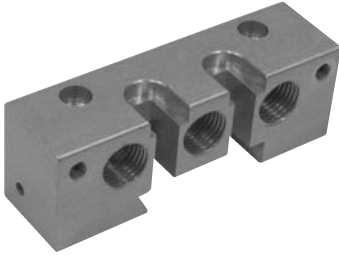

Per ogni batteria di valvole è necessario l'utilizzo di due terminali, uno destro e uno sinistro. Ogni terminale è venduto con i particolari necessari al suo assemblaggio.

Each manifold assembly requires a right and a left hand inlet header kit.

Each inlet header is sold with all necessary components.

CODICE DI ORDINAZIONE

ORDER CODE

07.009.2 terminale destro per sottobasi 1/8"
right hand header for 1/8" manifolds

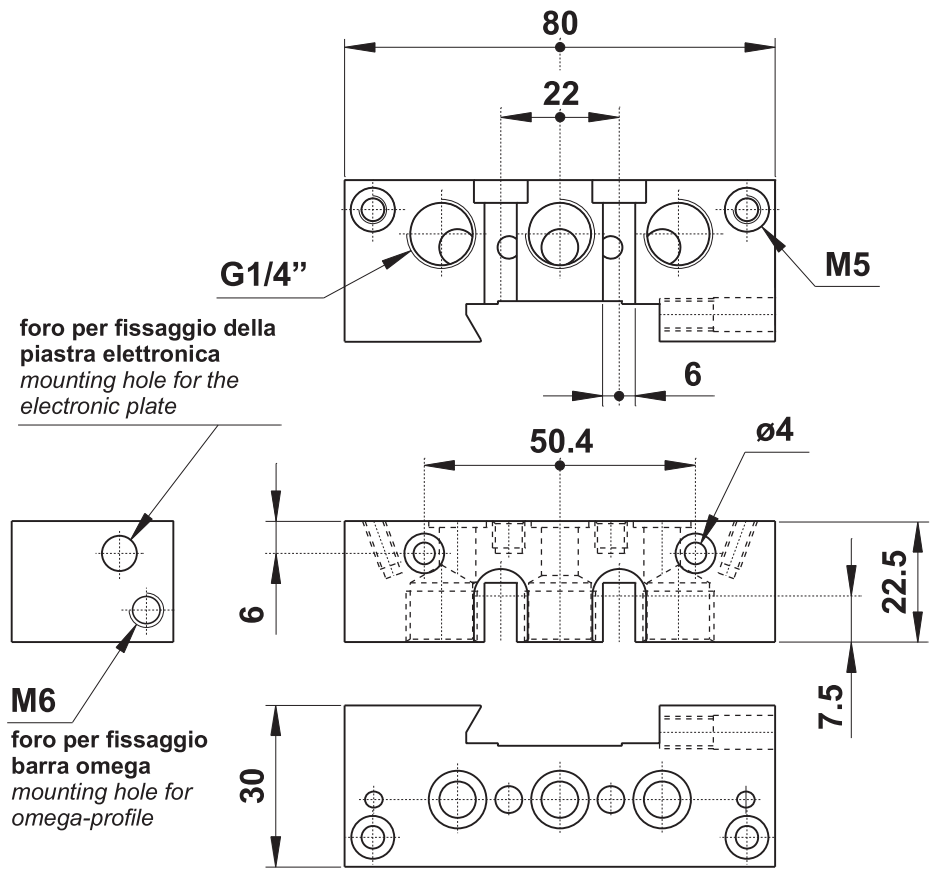

terminale sinistro G1/8"

G1/8" left inlet header



Per ogni batteria di valvole è necessario l'utilizzo di due terminali, uno destro e uno sinistro. Ogni terminale è venduto con i particolari necessari al suo assemblaggio.

Each manifold assembly requires a right and a left hand inlet header kit.

Each inlet header is sold with all necessary components.

CODICE DI ORDINAZIONE

ORDER CODE

07.010.2 terminale sinistro per sottobasi 1/8"
left hand header for 1/8" manifolds

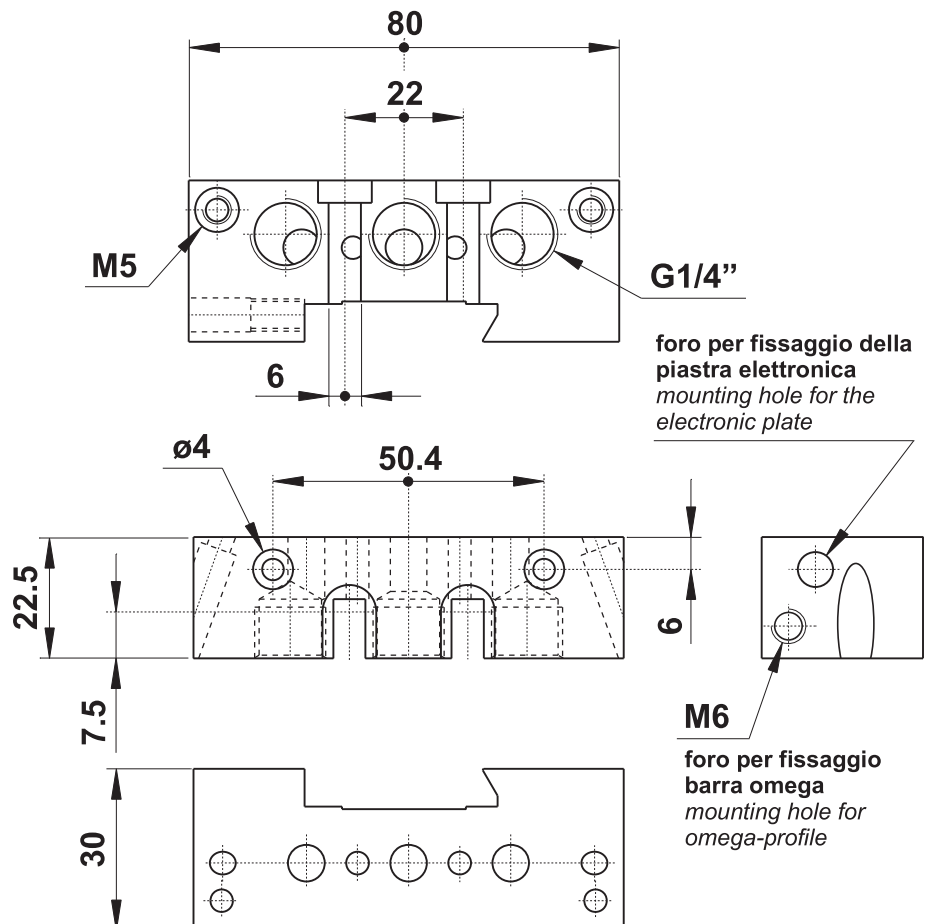

multiconnessione plug-in

plug-in multiconnection



terminale destro G1/4"

G1/4" right inlet header



Per ogni batteria di valvole è necessario l'utilizzo di due terminali, uno destro e uno sinistro. Ogni terminale è venduto con i particolari necessari al suo assemblaggio.

Each manifold assembly requires a right and a left hand inlet header kit.

Each inlet header is sold with all necessary components.

CODICE DI ORDINAZIONE

ORDER CODE

07.054.2 terminale destro per sottobasi 1/4"
right hand header for 1/4" manifolds

foro per fissaggio della piastra elettronica
mounting hole for the electronic plate

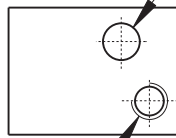

M6

foro per fissaggio barra omega
mounting hole for omega-profile

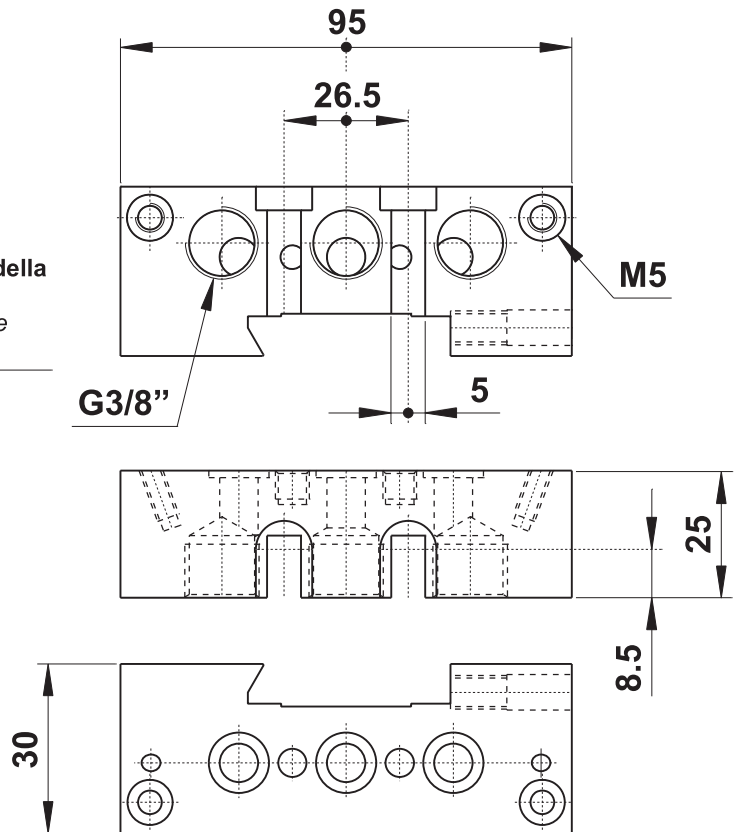

terminale sinistro G1/4"

G1/4" left inlet header

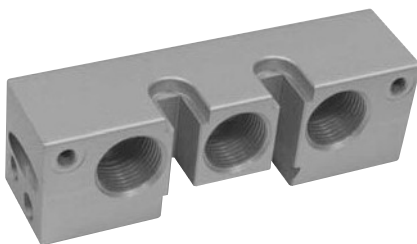

Per ogni batteria di valvole è necessario l'utilizzo di due terminali, uno destro e uno sinistro. Ogni terminale è venduto con i particolari necessari al suo assemblaggio.

Each manifold assembly requires a right and a left hand inlet header kit.

Each inlet header is sold with all necessary components.

CODICE DI ORDINAZIONE

ORDER CODE

07.055.2 terminale sinistro per sottobasi 1/4"
left hand header for 1/4" manifolds

foro per fissaggio della piastra elettronica
mounting hole for the electronic plate

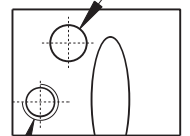

M6

foro per fissaggio barra omega
mounting hole for omega-profile

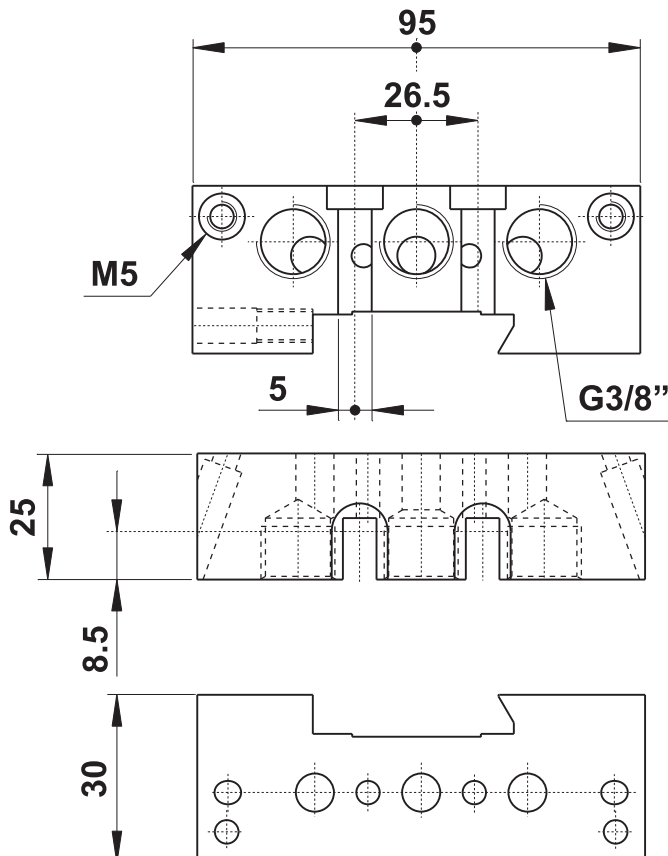

multiconnessione plug-in

plug-in multiconnection



riduzione G1/4"-G1/8" G1/4"-G1/8" reduction

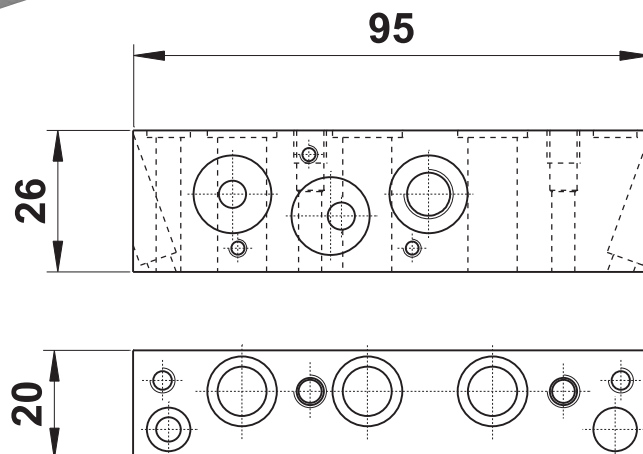
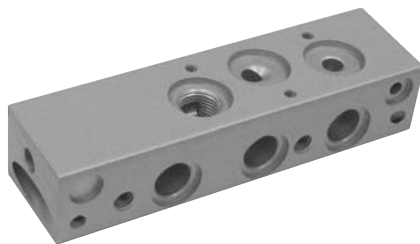

Questa sottobase di riduzione è utilizzata per l'installazione di valvole da 1/8" in una batteria di valvole da 1/4", formando così una batteria ibrida. È venduta con i particolari necessari per il fissaggio e il montaggio della valvola.

This reduction sub-base is used to assemble 1/8" valves on a 1/4" manifold, creating a hybrid manifold. It is sold in kit with all necessary components.

CODICE DI ORDINAZIONE - ORDER CODE

07.056.2

diaframma interno internal diaphragm



Questo diaframma deve essere collocato internamente tra un elemento e l'altro della batteria di valvole per interrompere il flusso dell'aria e dividere la batteria in due o più settori. Può essere utilizzato per interrompere solo l'alimentazione, solo gli scarichi o sia alimentazione sia scarichi. Può essere ordinato singolarmente, e in questo caso deve essere inserito manualmente smontando parzialmente la batteria di valvole, oppure può essere ordinato insieme alla batteria di valvole indicandolo opportunamente come specificato nella chiave di codifica della multiconnessione.

This diaphragm must be inserted between two elements of the manifold to interrupt the air flow and divide the manifold into two or more parts. It can be used to interrupt only the supply air flow, only the exhausts or both air supply and exhausts. It can be ordered as spare part, and in this case it must be manually inserted after having partly disassembled the manifold, or it can be ordered together with the valve manifold, indicating it in the order code as specified in the codes explanation of the multiconnection.

	1/8"	1/4"
A	10	12
B	6.6	8.8
C	3.2	3.2

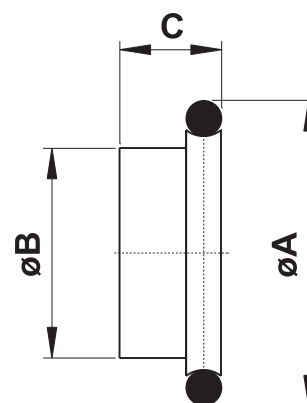

CODICI DI ORDINAZIONE - ORDER CODES

07.011.2 per batterie di valvole 1/8" - for 1/8" manifolds

07.057.2 per batterie di valvole 1/4" - for 1/4" manifolds

multiconnessione plug-in

plug-in multiconnection



Le sottobasi a posti fissi possono essere utilizzate per il fissaggio di valvole a 5 vie, da 1/8" o da 1/4". Ogni sottobase è venduta con i particolari necessari per il fissaggio e il montaggio delle valvole. Eventuali posizioni non utilizzate possono essere tappate con la piastrina di chiusura. Non è possibile combinare sulla stessa base valvole da 1/8" e da 1/4". Non è possibile l'installazione di valvole con alimentazione separata.

The fixed manifolds can be used for the installation of five way valves, 1/8" or 1/4". Each manifold is sold with all necessary pieces for installation. Unused stations can be closed with a blanking plate. It is not possible to mix on the same base 1/8" and 1/4" valves. The installation of valves with separate air supply is not possible.



1/8"

modello model	nr. posiz. no. stations	A	B
07.012.2	2	90	57
07.013.2	3	112.5	79.5
07.014.2	4	135	102
07.015.2	5	157.5	124.5
07.016.2	6	180	147
07.017.2	7	202.5	169.5
07.018.2	8	225	192
07.019.2	9	247.5	214.5
07.020.2	10	270	237
07.021.2	11	292.5	259.5
07.022.2	12	315	282

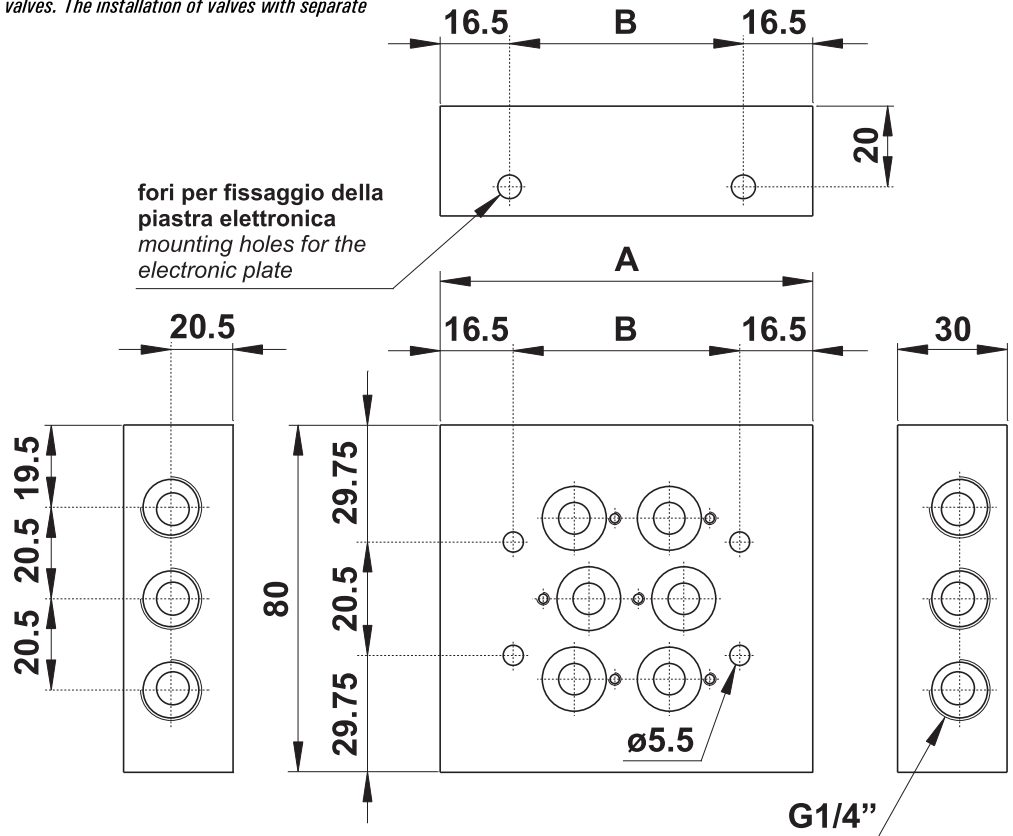

1/4"

modello model	nr. posiz. no. stations	A	B	C
07.062.2	2	102	62	64
07.063.2	3	128	88	90
07.064.2	4	154	114	116
07.065.2	5	180	140	142
07.066.2	6	206	166	168
07.067.2	7	232	192	194
07.068.2	8	258	218	220
07.069.2	9	284	244	246
07.070.2	10	310	270	272
07.071.2	11	336	296	298
07.072.2	12	362	322	324

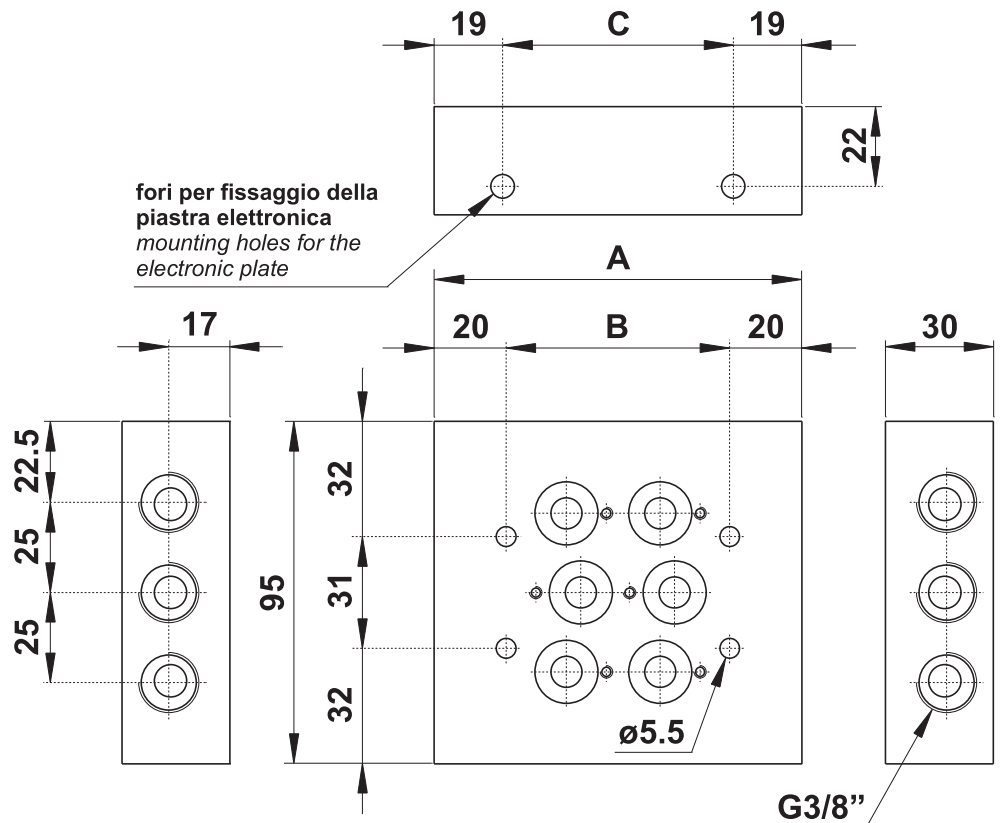

multiconnessione plug-in

plug-in multiconnection



piastra elettronica

electronic plate (rack)

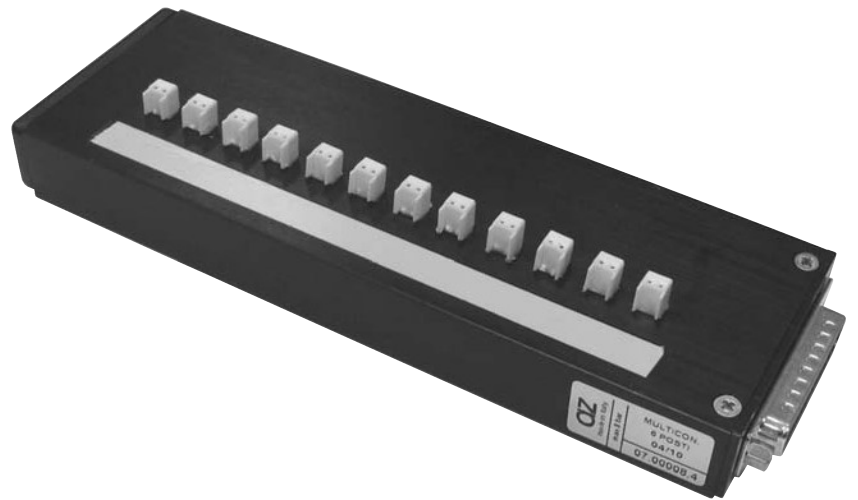
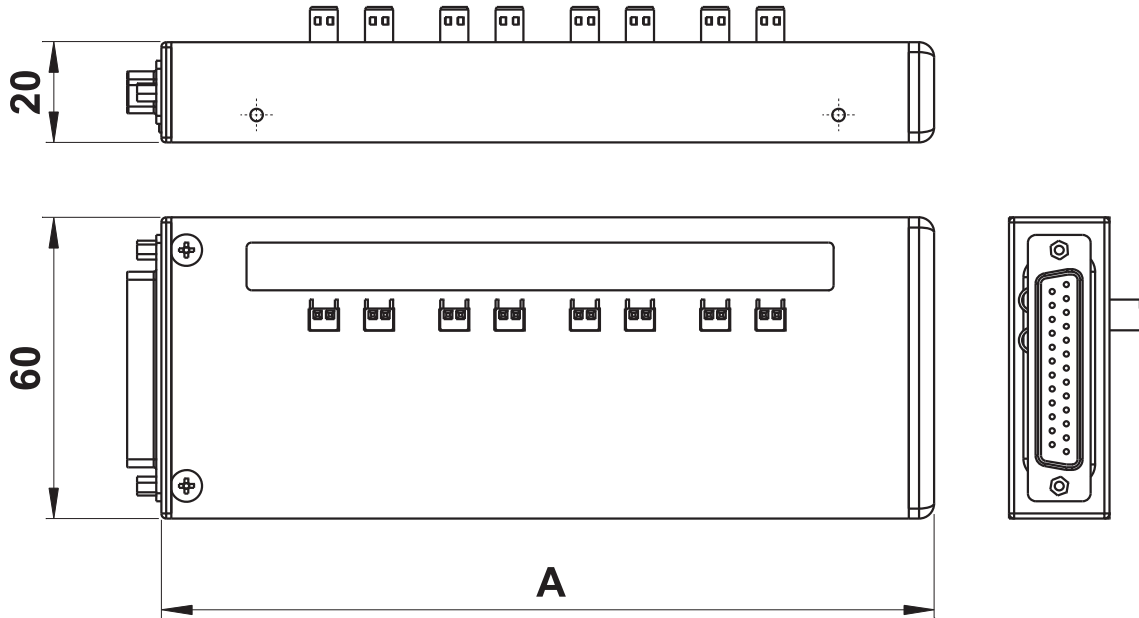

1/8"

modello model	nr. posiz. no. stations	A
07.041.2	2	90
07.023.2	3	112.5
07.024.2	4	135
07.025.2	5	157.5
07.026.2	6	180
07.027.2	7	202.5
07.028.2	8	225
07.029.2	9	247.5
07.030.2	10	270
07.031.2	11	292.5
07.032.2	12	315

1/4"

modello model	nr. posiz. no. stations	A
07.042.2	2	102
07.043.2	3	128
07.044.2	4	154
07.045.2	5	180
07.046.2	6	206
07.047.2	7	232
07.048.2	8	258
07.049.2	9	284
07.050.2	10	310
07.058.2	11	336
07.059.2	12	362

ACCESSORI - ACCESSORIES

- 07.125.0** Cavo 3 metri con connettore D-SUB 25
3 metres cable with connector D-SUB 25
- 07.126.0** Cavo 5 metri con connettore D-SUB 25
5 metres cable with connector D-SUB 25
- 07.127.0** Cavo 10 metri con connettore D-SUB 25
10 metres cable with connector D-SUB 25



La piastra elettronica è normalmente venduta insieme alla multiconnessione già configurata ma può essere acquistata anche separatamente. I cavi, contenuti all'interno della piastra, sono già preassemblati.

The electronic plate is normally sold together with the already configured multiconnection, but it can be sold also separately. The cables are already assembled inside the plate.

multiconnessione plug-in uscite in base

plug-in multiconnection with exit ports on the sub-base



- Valvole a spola: doppia 3/2, 5/2 e 5/3 con attacchi filettati G1/8"
Double 3/2, 5/2 and 5/3 spool valves with G1/8" threaded ports
- Comandi elettrici con azionamento manuale
Solenoid pilots with manual override
- Tensione 24V DC
Tension 24V DC
- Protezione elettrica IP 40
Electrical protection IP 40
- Potenza 0.5 ... 1W
Power 0.5 ... 1W
- Massimo 12 valvole bistabili o 24 monostabili
Maximum 12 bi-stable valves or 24 mono-stable



Materiali

Corpo: alluminio 11S

Fondelli: tecnopolimero (*) o alluminio

Molle: INOX

Guarnizioni: NBR

Spola: alluminio nichelato

Parti interne: ottone OT58

Materials

Body: aluminium 11S

End caps: technopolymer (*) or aluminium

Springs: stainless steel

Seals: NBR

Spool: nickel plated aluminium

Internal parts: brass OT58

(*) Le parti in tecnopolimero recano impresso il logo

(*) The parts in technopolymer are marked with the logo

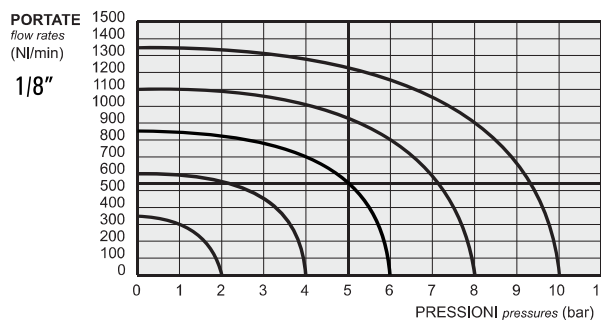

Diametro nominale <i>Nominal orifice</i>		1/8": 5 mm		
Temperatura di esercizio <i>Temperature range</i>		-5 ... +60°C		
Pressione di esercizio <i>Working pressure</i>	al. interna monost. [monost. internal air supply]	al. interna bist. [bi-stable internal air supply]	alim. separata [separate air supply]	
	2.5 ... 7 bar 0.25 ... 0.7 MPa	2.5 ... 7 bar 0.25 ... 0.7 MPa	-0.9 ... 10 bar -0.09 ... 1 MPa	
Pressione di azionamento (per alimentazione separata) <i>Actuating pressure (for separate air supply)</i>		monostabile [mono-stable]		bistabile [bi-stable]
		2.5 ... 7 bar 0.25 ... 0.7 MPa		2.5 ... 7 bar 0.25 ... 0.7 MPa
Fluido <i>Fluid</i>		Aria filtrata 5µ con o senza lubrificazione <i>5µ filtered, lubricated or non lubricated air</i>		

multiconnessione plug-in uscite in base

plug-in multiconnection with exit ports on the sub-base

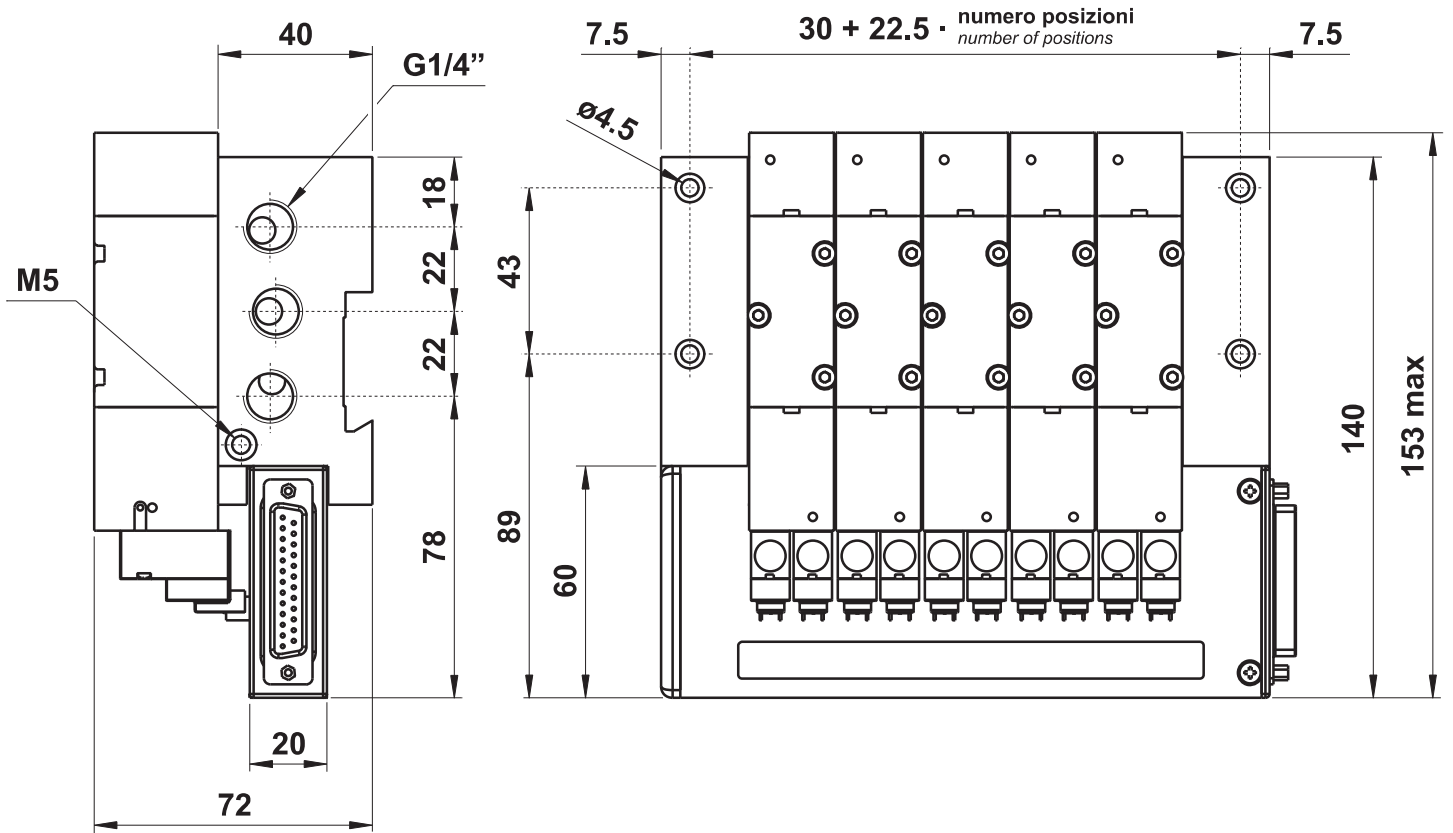

chiave di codifica

key to codes

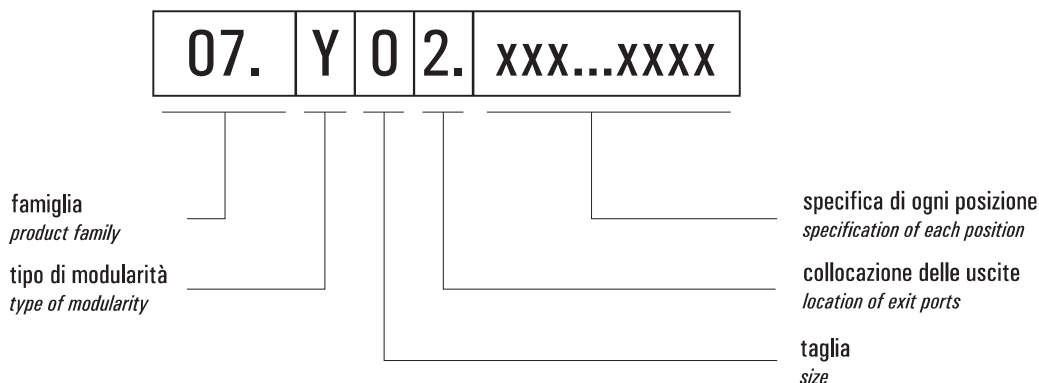

Famiglia *[product family]*

07 multiconnessione plug-in *[plug-in multiconnection]*

Tipo di modularità *[type of modularity]*

Y sottobasi modulari *[modular multiple sub-bases]*

Taglia *[size]*

0 G1/8" 22 mm

Collocazione delle uscite *[location of exit ports]*

2 in base *[on the sub-base]*

Specifica di ogni posizione *[specification of each position]*

RISPETTARE MAIUSCOLE E MINUSCOLE *CASE SENSITIVE*

G1/8"

- a** 521B ME
- b** 521B ME AS
- c** 521B EE
- d** 521B EED
- e** 521B EE AS
- f** 2x321B ME
- g** 2x321B ME AS
- h** 521B3C EE
- j** 521B3A EE
- k** 521B3P EE
- m** 521B3C EE AS
- n** 521B3A EE AS
- p** 521B3P EE AS
- q** 521B CE
- r** Piastrina di chiusura *[blanking plate]*
- s** Intermedio *[intermediate header]*
- t** Diaframma alimentazione
[diaphragm on air supply]
- u** Diaframma scarichi
[diaphragm on exhausts]
- v** Diaframma alimentazione+ scarichi
[diaphragm on air supply and exhausts]

Le valvole, le parti elettroniche e le sottobasi con i relativi elementi accessori sono compresi e premontati nella multiconnessione ordinata secondo la presente chiave di codifica, non è pertanto necessario ordinarli separatamente.

Valves, electronic parts and sub-bases with accessories are included and preassembled in the multiconnection manifold ordered according to these codes. It is not necessary to order them separately.

multiconnessione plug-in uscite in base

plug-in multiconnection with exit ports on the sub-base



521B EE

5/2 1/8" doppio comando elettrico
5/2 1/8" double solenoid pilot

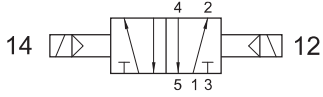

521B EED

5/2 1/8" doppio comando elettrico - con differenziale
5/2 1/8" double solenoid pilot - with differential

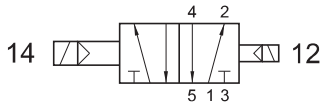

2x321B ME

doppia 3/2 1/8" comando elettrico - ritorno a molla
double 3/2 1/8" solenoid pilot - spring return

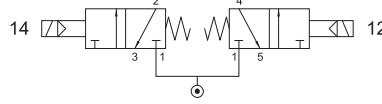

2x321B ME AS

doppia 3/2 1/8" comando elettrico alimentazione separata - ritorno a molla
double 3/2 1/8" solenoid pilot with separate air supply - spring return

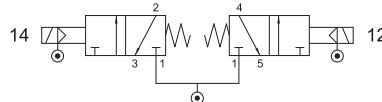

521B EE AS

5/2 1/8" doppio comando elettrico alimentazione separata
5/2 1/8" double solenoid pilot with separate air supply

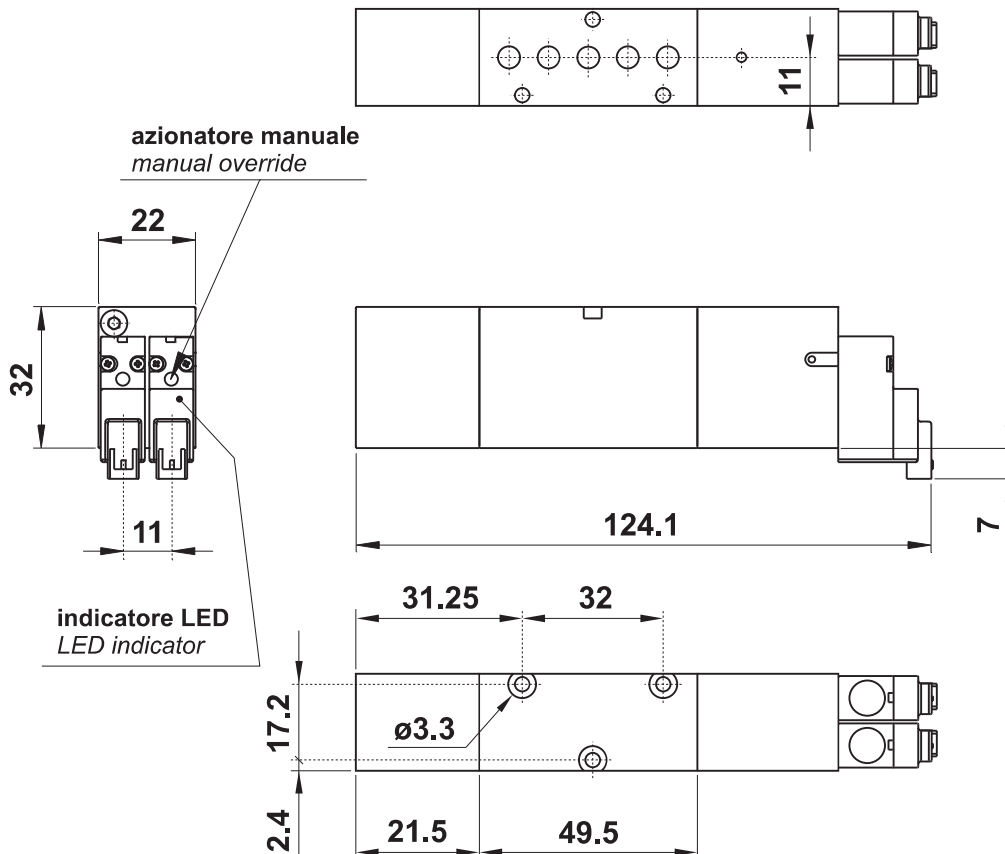
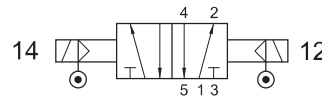

multiconnessione plug-in uscite in base

plug-in multiconnection with exit ports on the sub-base



521B3C EE

centri chiusi
closed centres

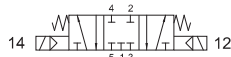

521B3C EE AS

centri chiusi
closed centres

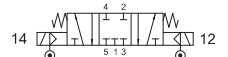

521B3A EE

centri aperti
open centres

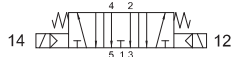

521B3A EE AS

centri aperti
open centres

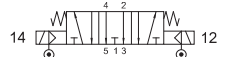

521B3P EE

centri in pressione
pressurized centres

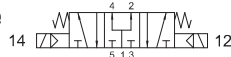

521B3P EE AS

centri in pressione
pressurized centres

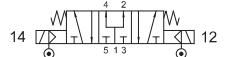

5/3 1/8" doppio comando elettrico

5/3 1/8" double solenoid pilot

5/3 1/8" doppio comando elettrico alimentazione separata

5/3 1/8" double solenoid pilot with separate air supply

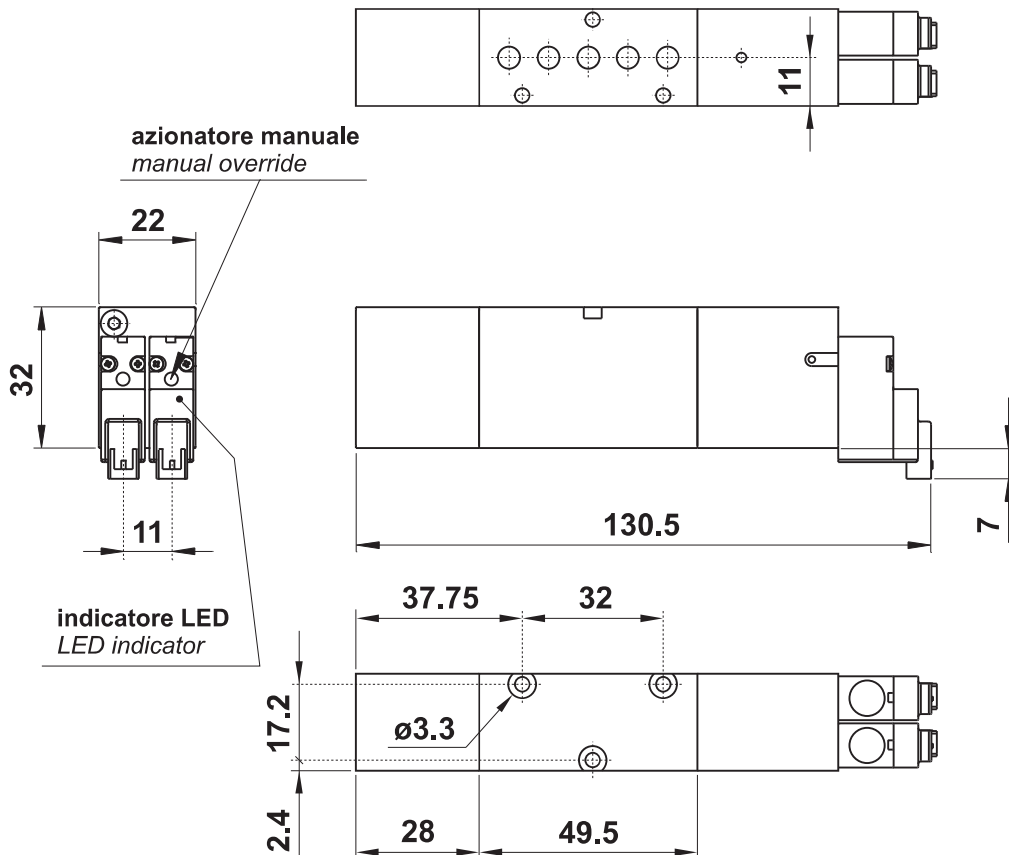
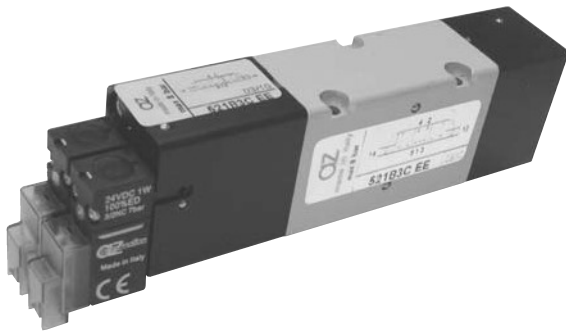

multiconnessione plug-in uscite in base

plug-in multiconnection with exit ports on the sub-base



sottobase singola single sub-base

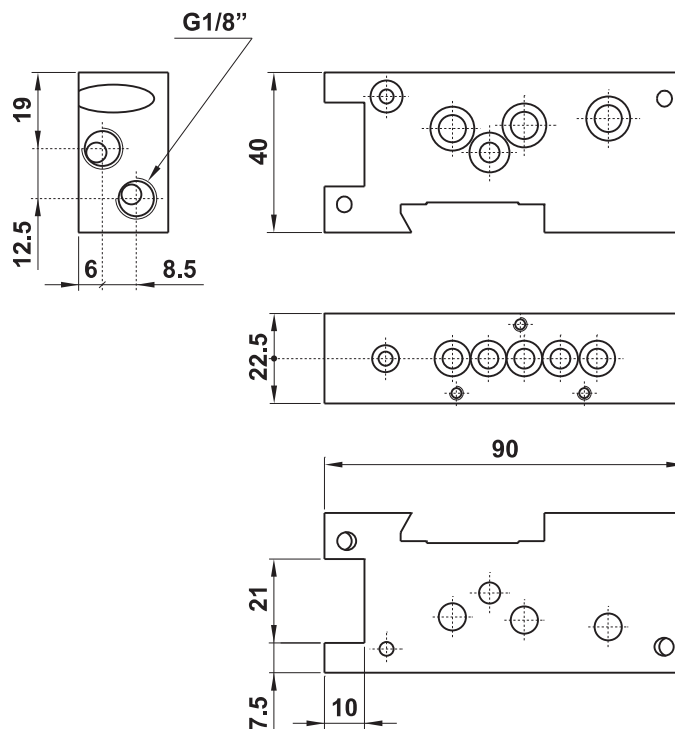
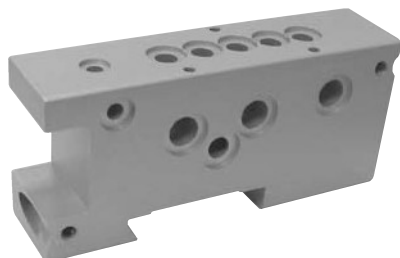

Le sottobasi devono essere utilizzate per il fissaggio delle valvole. Ogni sottobase è venduta con i particolari necessari per il fissaggio e il montaggio della valvola.

Each sub-base is sold with all necessary components to install the valve.

CODICE DI ORDINAZIONE

ORDER CODE

07.102.2 sottobase singola
single sub-base

sottobase doppia double sub-base

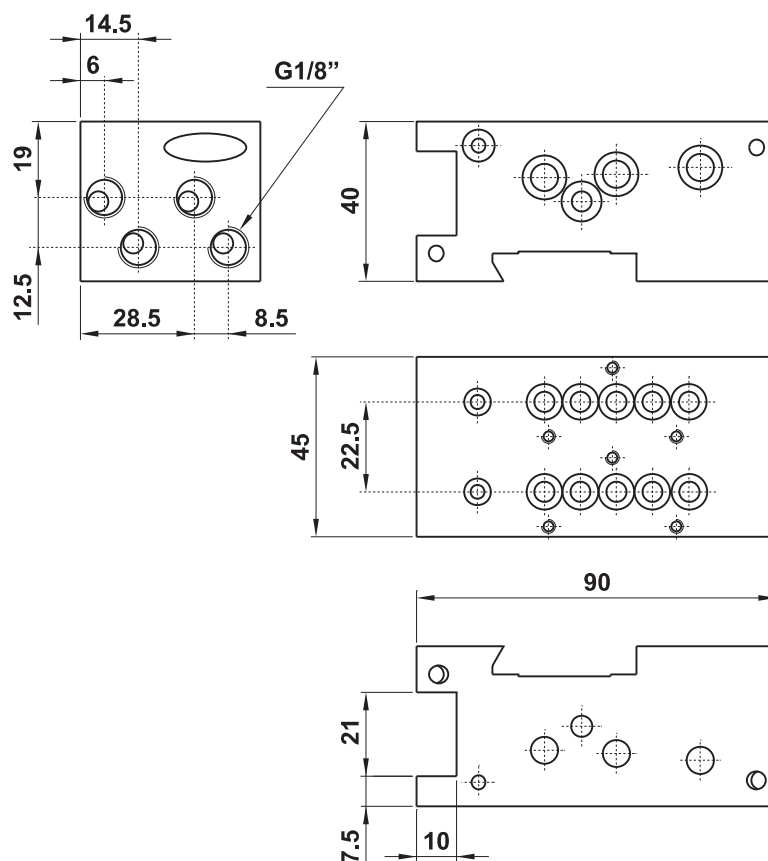

Le sottobasi devono essere utilizzate per il fissaggio delle valvole. Ogni sottobase è venduta con i particolari necessari per il fissaggio e il montaggio delle valvole.

Each sub-base is sold with all necessary components to install the valves.

CODICE DI ORDINAZIONE

ORDER CODE

07.103.2 sottobase doppia
double sub-base

multiconnessione plug-in uscite in base

plug-in multiconnection with exit ports on the sub-base



terminale destro right inlet header

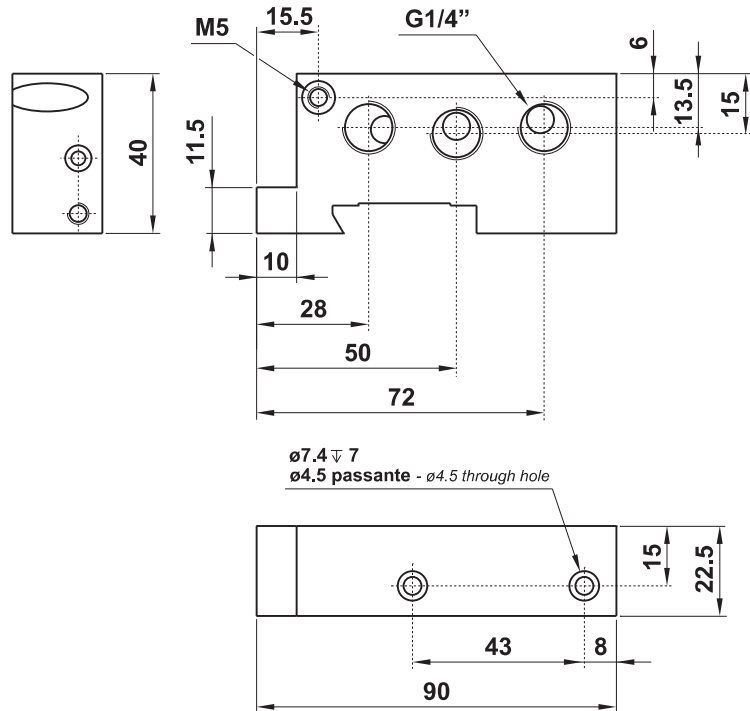

Per ogni batteria di valvole è necessario l'utilizzo di due terminali, uno destro e uno sinistro. Ogni terminale è venduto con i particolari necessari al suo assemblaggio.

Each manifold assembly requires a right and a left hand inlet header kit.

Each inlet header is sold with all necessary components.

CODICE DI ORDINAZIONE

ORDER CODE

07.105.2 terminale destro
right hand header

terminale sinistro left inlet header

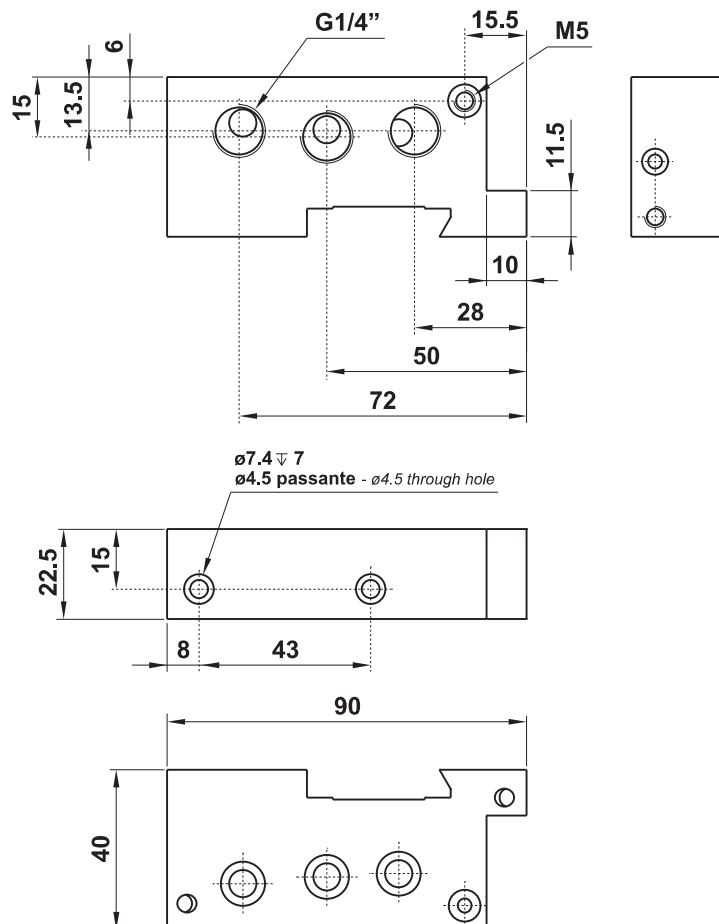

Per ogni batteria di valvole è necessario l'utilizzo di due terminali, uno destro e uno sinistro. Ogni terminale è venduto con i particolari necessari al suo assemblaggio.

Each manifold assembly requires a right and a left hand inlet header kit.

Each inlet header is sold with all necessary components.

CODICE DI ORDINAZIONE

ORDER CODE

07.104.2 terminale sinistro
left hand header

multiconnessione plug-in uscite in base

plug-in multiconnection with exit ports on the sub-base



intermedio intermediate header

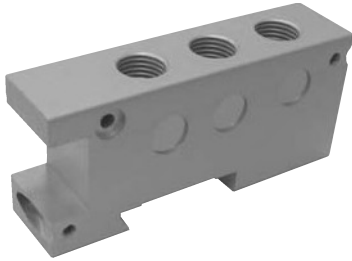

L'intermedio è utilizzabile per dividere una batteria di valvole in due parti e immettere l'aria per l'alimentazione di una delle due attraverso le connessioni di cui è dotato, e/o per dividere in due parti gli scarichi convogliati. È venduto con i pezzi necessari al suo assemblaggio.

An intermediate header with separate air supply is available to be installed in a manifold system which requires mixed operating pressures. It can be used also to divide the common exhausts. It is sold with all necessaries components for installation.

CODICE DI ORDINAZIONE - ORDER CODE

07.106.2 intermedio - intermediate header

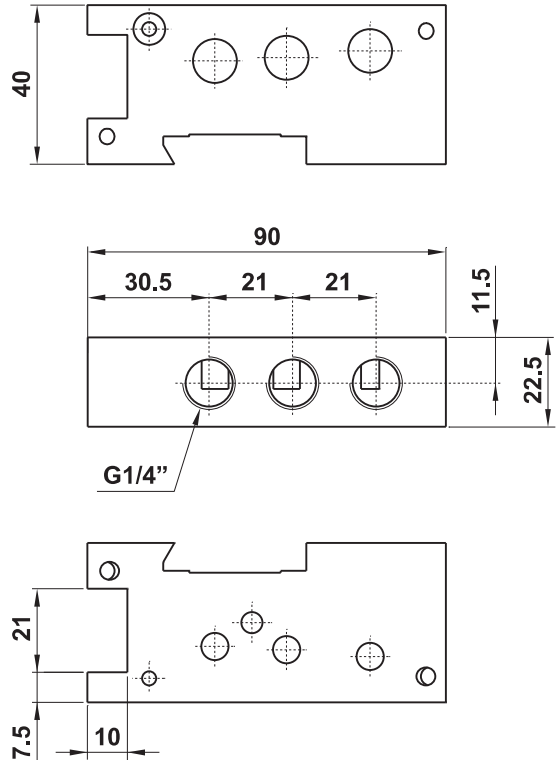

piastrina di chiusura blanking plate



	1/8"
A	80
D	22

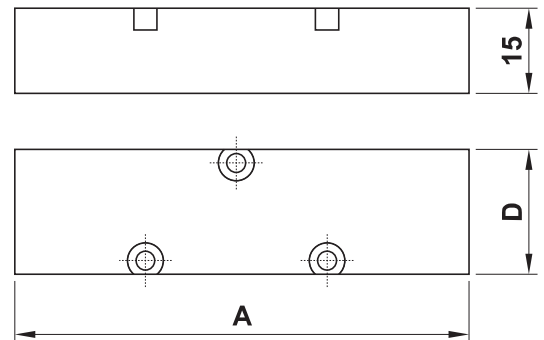

Venduta completa di viti, chiude i fori di sottobasi eventualmente non utilizzate.
The blanking plate with gasket and screws is available to close manifold stations not in use.

CODICE DI ORDINAZIONE - ORDER CODE

00.011.3 per sottobasi 1/8" - for 1/8" sub-bases

diaframma interno internal diaphragm



	A	B	C
1/8"	10	6.6	3.2

Questo diaframma deve essere collocato internamente tra un elemento e l'altro della batteria di valvole per interrompere il flusso dell'aria e dividere la batteria in due o più settori. Può essere utilizzato per interrompere solo l'alimentazione, solo gli scarichi o sia alimentazione sia scarichi. Può essere ordinato singolarmente, e in questo caso deve essere inserito manualmente smontando parzialmente la batteria di valvole, oppure può essere ordinato insieme alla batteria di valvole indicandolo opportunamente come specificato nella chiave di codifica della multiconnessione.

This diaphragm must be inserted between two elements of the manifold to interrupt the air flow and divide the manifold into two or more parts. It can be used to interrupt only the supply air flow, only the exhausts or both air supply and exhausts. It can be ordered as spare part, and in this case it must be manually inserted after having partly disassembled the manifold, or it can be ordered together with the valve manifold, indicating it in the order code as specified in the codes explanation of the multiconnection.

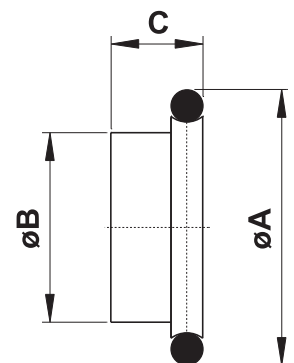

CODICE DI ORDINAZIONE - ORDER CODE

07.011.2 per batterie di valvole 1/8" - for 1/8" manifolds

multiconnessione plug-in uscite in base

plug-in multiconnection with exit ports on the sub-base



fissaggio delle sottobasi dalla parte superiore

manifold mounting from the top side

basi modulari

multiple sub-bases

1

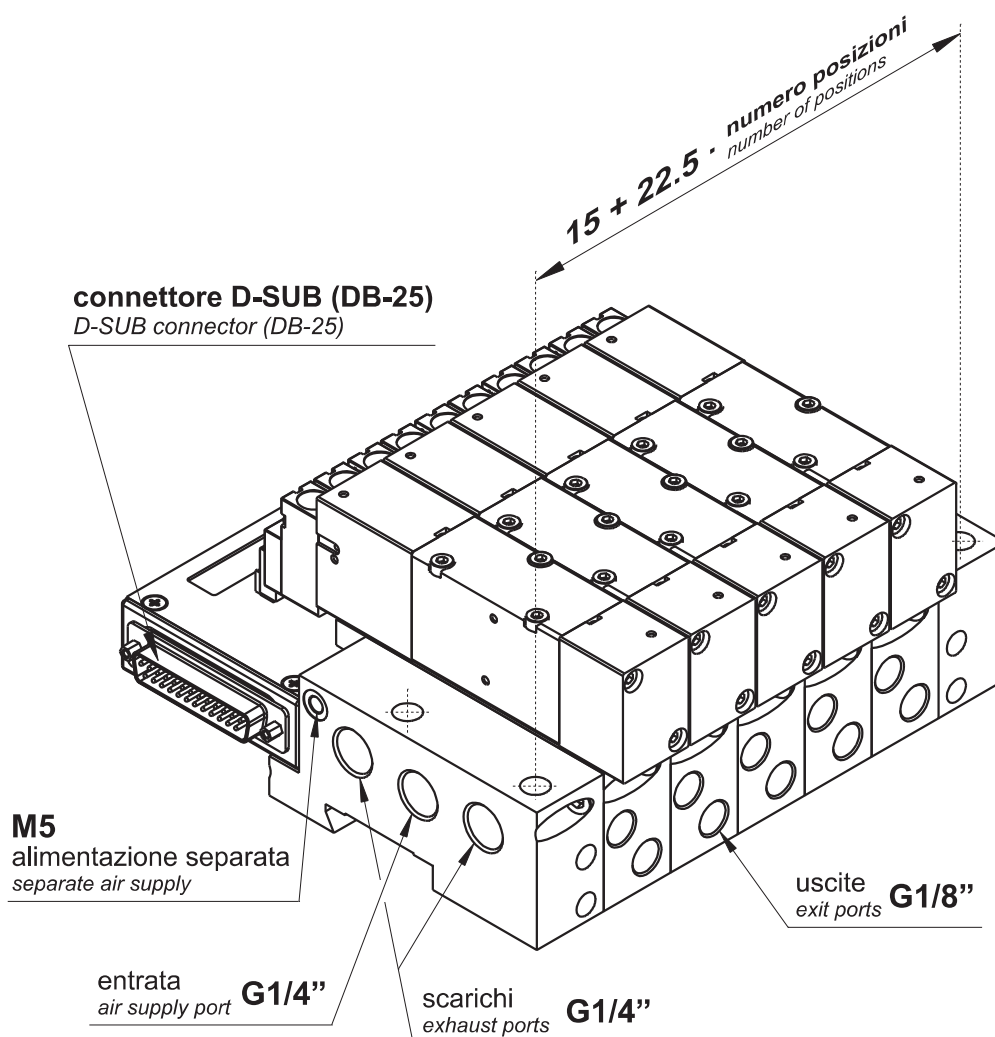

La base può essere fissata anche su barra omega.

The manifold can be mounted on omega-profile too.

connettore D-SUB (DB-25)

connector D-SUB (DB-25)

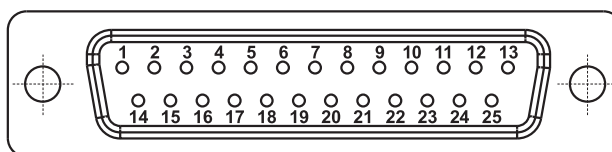

1-24 segnali per elettropiloti
signals for solenoid valves

25 comune (-)
common (-)